

## SEDM

# Multi compartment smoke control damper

Technical Documentation

Installation, Commissioning, Operation, Maintenance and Service Manual

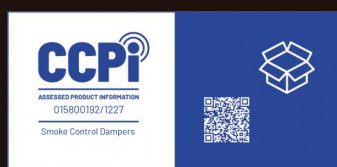
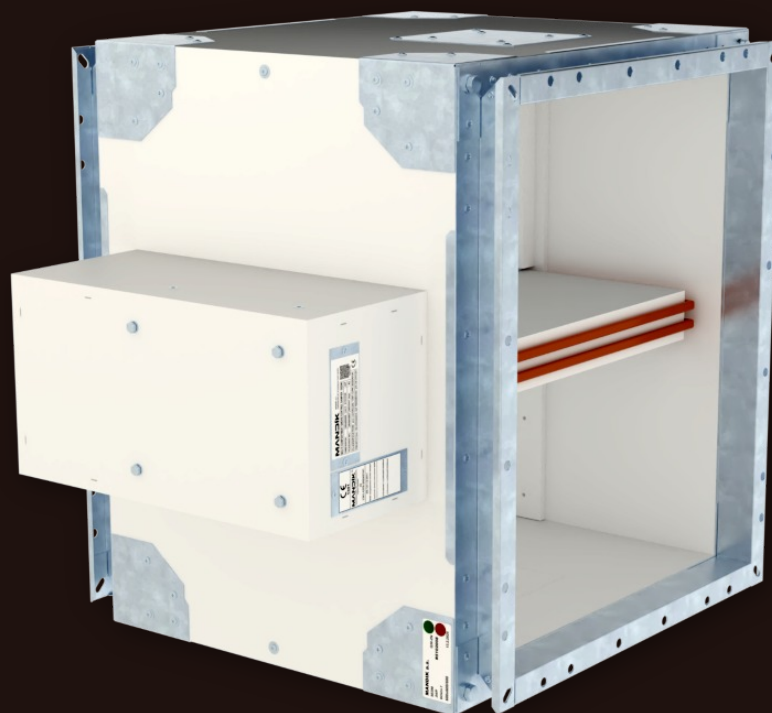

These technical specifications state a row of manufactured sizes and models of Multi compartment smoke control damper SEDM. It is valid for production, designing, ordering, delivery, maintenance and operation.

# CONTENT

I. GENERAL.....	3
Description.....	3
II. DESIGN.....	4
Design with actuating mechanism.....	4
Communication and control module MDCM.....	9
Communication and control module MDPM.....	9
III. DIMENSIONS.....	10
Technical parameters.....	12
IV. INSTALLATION.....	24
Placement and installation.....	24
Statement of installations.....	25
Installation in solid wall construction of fire compartment.....	26
Installation in gypsum wall construction of fire compartment.....	27
Installation in solid ceiling construction of fire compartment.....	28
Installation in battery.....	29
Installation into/onto vertical or horizontal smoke extraction duct.....	33
V. SUSPENSION SYSTEMS.....	35
Example of duct connection.....	42
VI. ACCESSORIES.....	45
VII. TECHNICAL DATA.....	46
Pressure loss.....	46
Noise data - level of acoustic output corrected with filter A.....	48
VIII. MATERIAL, FINISHING.....	54
IX. TRANSPORTATION AND STORAGE.....	54
Logistic terms.....	54
X. ASSEMBLY, ATTENDANCE AND MAINTENANCE.....	55
Electrical connection of the actuator in protection box.....	55
Connection of the control module MDPM & MDCM interfaces inside protection box.....	56
Entry into service and revisions.....	57
XI. ORDERING INFORMATION.....	58
Ordering key.....	58
Accessories.....	59
Data label.....	59

# I. GENERAL

## Description

Dampers SEDM are designed into an inlet or extract smoke ventilation system. The dampers are designed either to close to provide compartmentalization or to open (for fresh air inlet) or to allow removal of the heat and combustible products from a fire in the affected fire zone/compartment.

The damper blade is controlled by electrical actuating mechanism.

Dampers are fire resistant and are intended for systems with manual or automatic activation.

Dampers are designed for using in fire compartments that can be connected to the smoke exhaust ducts (tested according to BS EN 1366-8) or they can be installed in or on the construction of the fire compartment.

Dampers can be delivered with or without flange(s), with cover grille(s).

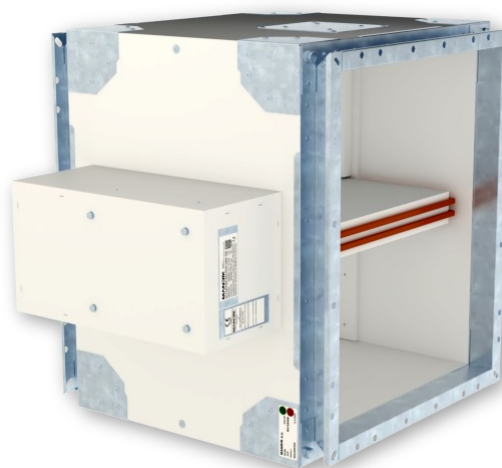

*Damper SEDM*

### Damper characteristics

- CE certified acc. to BS EN 12101-8
- Tested in accordance with BS EN 1366-10
- Classified acc. to BS EN 13501-4
- External Casing leakage class ATC 3 (old marking "C"), Internal leakage min. class 2 acc. to BS EN 1751
- Cycling test in class C<sub>mod</sub> acc. to BS EN 12101-8
- Certificate of constancy of performance UKCA No. 2822-UKCA-CPR-XXXX
- Certificate of constancy of performance CE No. 1391-CPR-XXXX/XXXX
- Declaration of Performance UKCA No. PM/SEDM/02/XX/X
- Declaration of Performance CE No. PM/SEDM/01/XX/X
- Hygienic assessment - Report No. 1.6/pos/19/19b

### Classification of Dampers

Supporting construction	Installation type	Classification
Horizontal or vertical smoke extraction ducts	Connection to single or multi compartment smoke extraction ducts tested according to BS EN 1366-8 or 9	EI 120 (h <sub>od</sub> -V <sub>ed</sub> i↔o) S1000C <sub>mod</sub> HOT 400/30MAmulti*
In solid/ gypsum plasterboard wall construction, min. thickness 100 mm	Ablative Coated Batt	EI 120 (V <sub>ew</sub> i↔o) S1500C <sub>mod</sub> HOT 400/30MAmulti*
In solid ceiling construction, min. thickness 150 mm		EI 120 (h <sub>ow</sub> i↔o) S1500C <sub>mod</sub> HOT 400/30AAmulti*

\* In practice dampers are not in the open position at the beginning of smoke threat.

### Working conditions

- Exact damper function is provided under the following conditions
  - maximum air velocity 15 m/s
  - underpressure max. -1500 Pa or overpressure max. 500 Pa
- Dampers are designed for installation in vertical or horizontal openings of fire separating constructions.
- The damper may be in any position between the position open and closed (those positions included) at the beginning of the risk of fire. Command to close the damper shall be started within 30 seconds from the beginning of the risk of fire, command to open the damper shall be started within 25 minutes for Manual activation (MA) from the beginning of the risk of fire, or within 30 seconds for Automatic activation (AA) respectively.
- Dampers are designed for macroclimatic areas with mild climate according to BS EN IEC 60 721-3-3 ed.2., class 3K22. (Environment 3K22 is typically protected place with regulated temperature).
- Temperature in the place of installation is permitted to range from -30°C to +50°C.

## II. DESIGN

### Design with actuating mechanism

#### Design .44 and .54

- Belimo actuators are used for dampers, series BEN, BEE, BE for 230V AC resp. 24 V AC/DC, Schischek InMax 50.75-S actuators (universal 24V or 230V supply) are used for large size of dampers.
- After connection to the power supply voltage, the actuator moves the damper blade to the "OPEN" position or "CLOSED" (according to the corresponding connection, see wiring diagram). If the power supply is interrupted, the actuator stops at the current position. The signalling of the "OPEN" and "CLOSED" damper blade positions is ensured by two built-in fixed "potential-free" end- limit switches.
- The actuator for operating the damper blade is mounted in an insulated cover/box. It is accessible after removing the cover lid. The electrical connection of the actuator is made with a non-flammable cable (or a cable located in the adjoining cable duct), which passes through an opening made in the wall of the insulated cover/box when installing the damper or when connecting the actuator power cable. The power and control cable must be Cat 3 as BS EN8519.

#### Design .65

- Belimo modulating actuators, BEN (BEE)-SR series for 24V AC/DC are specially designed for remote control of smoke control dampers. The position of the damper blade is adjustable by means of control voltage 0 (2)...10V DC.
  - The signalling of the "OPEN" and "CLOSED" damper blade positions is ensured by two built-in fixed "potential-free" limit switches.
  - The actuator for operating the damper blade is mounted in an insulated cover/box. It is accessible after removing
- the cover lid. The electrical connection of the actuator is made with non-flammable cables (or cables located in the adjoining cable duct), which pass through an opening made in the wall of the insulated cover when installing the damper or when connecting the power cables of the actuator. The power and control cable must be Cat 3 as BS EN8519.

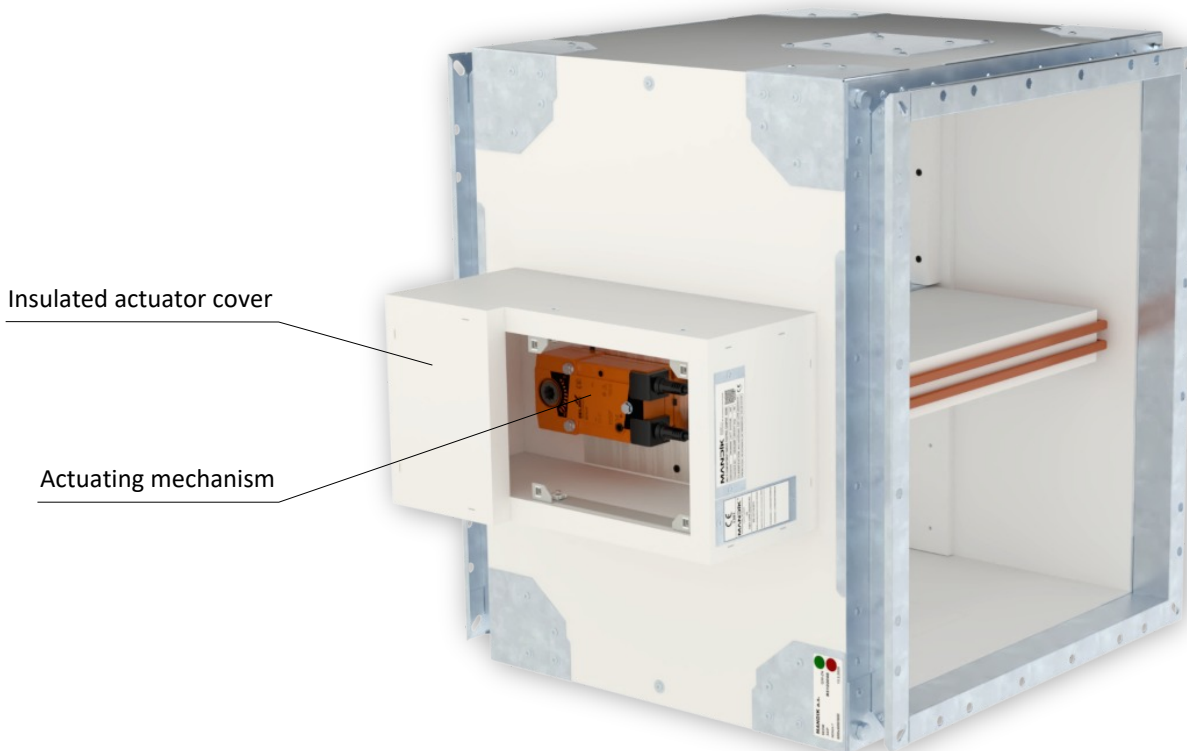

Design .44, .54 and .65

**Actuator BELIMO BEN 24(-ST)**

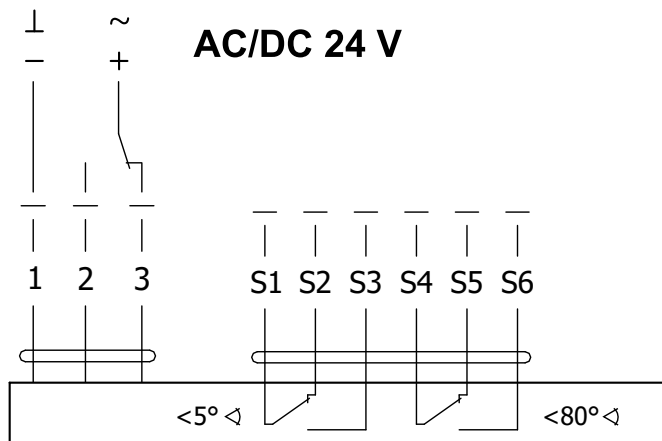

**Actuator BELIMO BEN 24-SR**

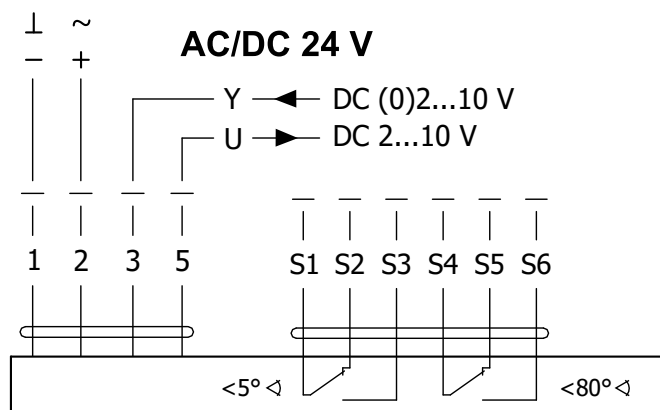

**Actuator BELIMO BEN 230**

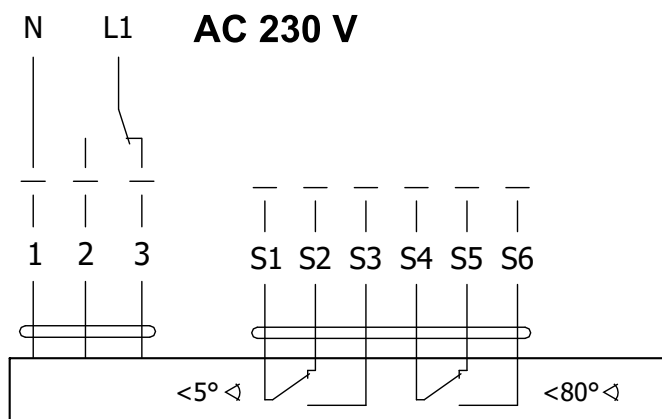

Extended leads are not possible with smoke control dampers as the belimo cabls are not fire rated to a high Field wiring must be brought into and terminated within the damper housing. For more detail → see pages 55 to 57, paragraph Assembly.

**Actuator BELIMO BEN 24(-ST), BEN 24-SR, BEN 230**

Actuator BELIMO - 15 Nm	BEN 24(-ST)	BEN 24-SR*	BEN 230
Power voltage	AC/DC 24 V 50/60Hz	AC/DC 24 V 50/60Hz	AC 230 V 50/60Hz
Power consumption - in operation - in the end position	3 W 0,1 W	3 W 0,3 W	4 W 0,4 W
Dimensioning	6 VA (Imax 8,2 A @ 5 ms)	6,5 VA (Imax 8.2 A @ 5 ms)	7 VA (Imax 4 A @ 5 ms)
Protection class	III	III	II
Degree of protection		IP 54	
Adjustment time for 95°		< 30 s	
Ambient temperature		-30°C ... +55°C	
Storage temperature		-40°C ... +80°C	
Connection - drive - auxiliary switch	Cable 1 m, 3 x 0,75 mm <sup>2</sup> Cable 1 m, 6 x 0,75 mm <sup>2</sup> (BEN 24-ST) with plug connectors	Cable 1 m, 4 x 0,75 mm <sup>2</sup> Cable 1 m, 6 x 0,75 mm <sup>2</sup>	Cable 1 m, 3 x 0,75 mm <sup>2</sup> Cable 1 m, 6 x 0,75 mm <sup>2</sup>

\* Only available for 24V and selected damper sizes

Actuator BELIMO BEE 24(-ST)

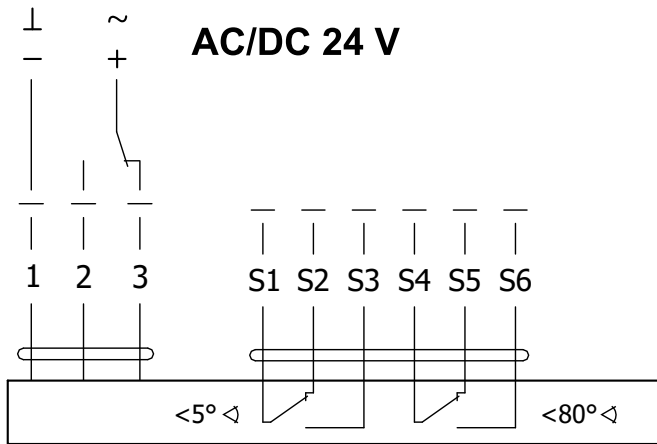

Actuator BELIMO BEE 24-SR

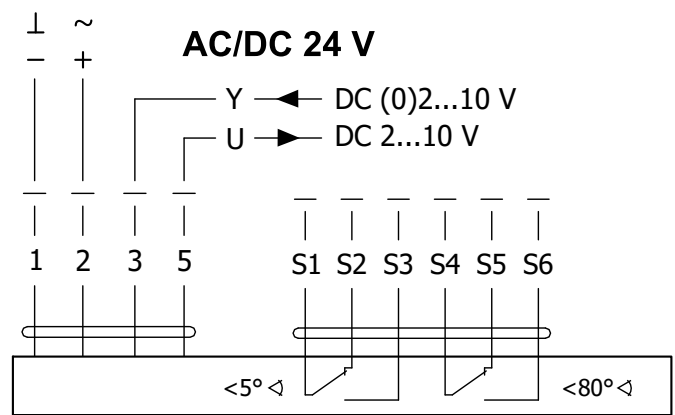

Actuator BELIMO BEE 230

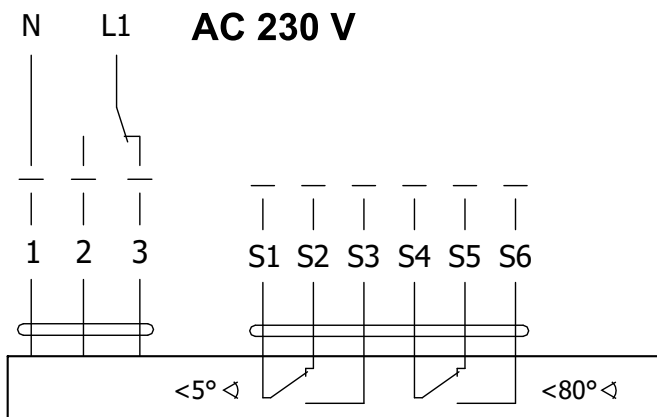

Extended leads are not possible with smoke control dampers as the belimo cabls are not fire rated to a high Field wiring must be brought into and terminated within the damper housing. For more detail → see pages 55 to 57, paragraph Assembly.

Actuator BELIMO BEE 24(-ST), BEE 24-SR, BEE 230

Actuator BELIMO - 25 Nm	BEE 24(-ST)	BEE 24-SR*	BEE 230
Power voltage	AC/DC 24 V 50/60Hz	AC/DC 24 V 50/60Hz	AC 230 V 50/60Hz
Power consumption - in operation - in the end position	2,5 W 0,1 W	3 W 0,3 W	3,5 W 0,4 W
Dimensioning	5 VA (Imax 8,2 A @ 5 ms)	5,5 VA (Imax 8.2 A @ 5 ms)	6 VA (Imax 4 A @ 5 ms)
Protection class	III	III	II
Degree of protection		IP 54	
Adjustment time for 95°		< 60 s	
Ambient temperature Storage temperature		-30°C ... +55°C -40°C ... +80°C	
Connection - drive - auxiliary switch	Cable 1 m, 3 x 0,75 mm <sup>2</sup> Cable 1 m, 6 x 0,75 mm <sup>2</sup> (BEE 24-ST) with plug connectors	Cable 1 m, 4 x 0,75 mm <sup>2</sup> Cable 1 m, 6 x 0,75 mm <sup>2</sup>	Cable 1 m, 3 x 0,75 mm <sup>2</sup> Cable 1 m, 6 x 0,75 mm <sup>2</sup>

\* Only available for 24V and selected damper sizes

**Actuator BELIMO BE 24-12(-ST)**

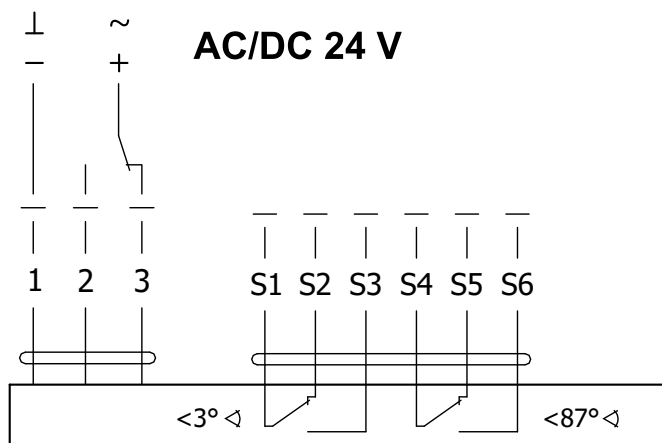

**Actuator BELIMO BE 230-12**

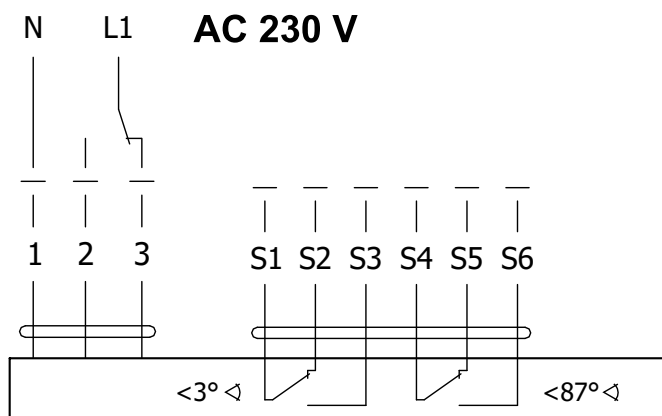

Extended leads are not possible with smoke control dampers as the belimo cables are not fire rated to a high Field wiring must be brought into and terminated within the damper housing. For more detail → see pages 55 to 57, paragraph Assembly.

**Actuator BELIMO BE 24-12(-ST), BE 230-12**

Actuator BELIMO - 40 Nm	BE 24-12(-ST)	BE 230-12
Power voltage	AC/DC 24 V 50/60Hz	AC 230 V 50/60Hz
Power consumption - in operation - in the end position	12 W 0,5 W	8 W 0,5 W
Dimensioning	18 VA (I <sub>max</sub> 8,2 A @ 5 ms)	15 VA (I <sub>max</sub> 7.9 A @ 5 ms)
Protection class	III	II
Degree of protection	IP 54	
Adjustment time for 95°	< 60 s	
Ambient temperature	-30°C ... +55°C	
Storage temperature	-40°C ... +80°C	
Connection - drive - auxiliary switch	Cable 1 m, 3 x 0,75 mm <sup>2</sup> Cable 1 m, 6 x 0,75 mm <sup>2</sup> (BE 24-ST) with plug connectors	

Actuator SCHISCHEK InMax 50.75-S

24...230 VAC/DC

Integrated aux. switches  
max 24V/3A, 240V/0,25A switching  
at 5° and 85°.

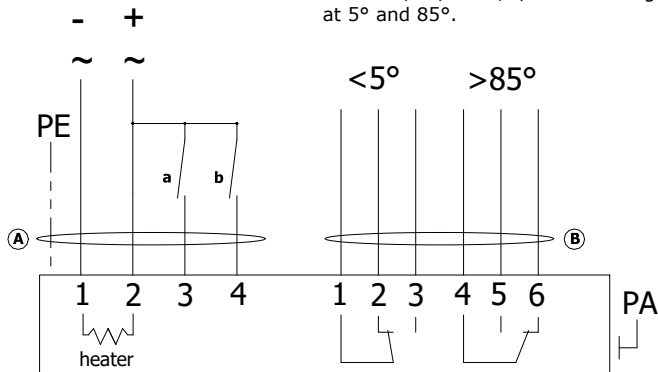

Extended leads are not possible with smoke control dampers as the belimo cabls are not fire rated to a high Field wiring must be brought into and terminated within the damper housing. For more detail → see pages 55 to 57, paragraph Assembly.

Actuator SCHISCHEK InMax 50.75-S

Actuator SCHISCHEK	InMax 50.75-S
Power voltage	24-240 VAC/DC 50/60Hz
Power consumption - motoring - heating	10 W 16 W (start at -20°C)
Protection class	I
Degree of protection	IP 66
Adjustment time for 95°	< 60 s
Ambient temperature	-40°C ... +50°C
Storage temperature	-40°C ... +70°C
Connection	Cable 1 m, 0,5 mm <sup>2</sup>

### Communication and control module MDCM

- The MDCM damper control module is connected on a bi directional communication loop back to a control panel, typically located at the FCC.
- Each MDCM has a 230v local spur to power the damper actuator.
- Max terminal size in MDCM and MDPM 2.5mm<sup>2</sup>
- Up to 96x MDCM's can be connected on one loop and multiple loops can be incorporated.
- With an MA or AA system the MDCM's are mounted in a fire rated and tested Ca-Si housing to BS EN1366-10.

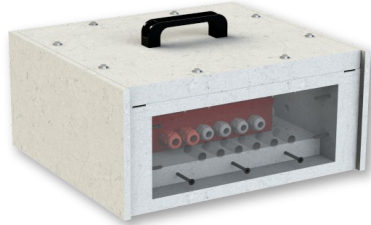

Details of connection of the control module interfaces inside protection box → see page 56

S90 mounted in an addressables smoke control damper control panel to BS ISO 21927-9

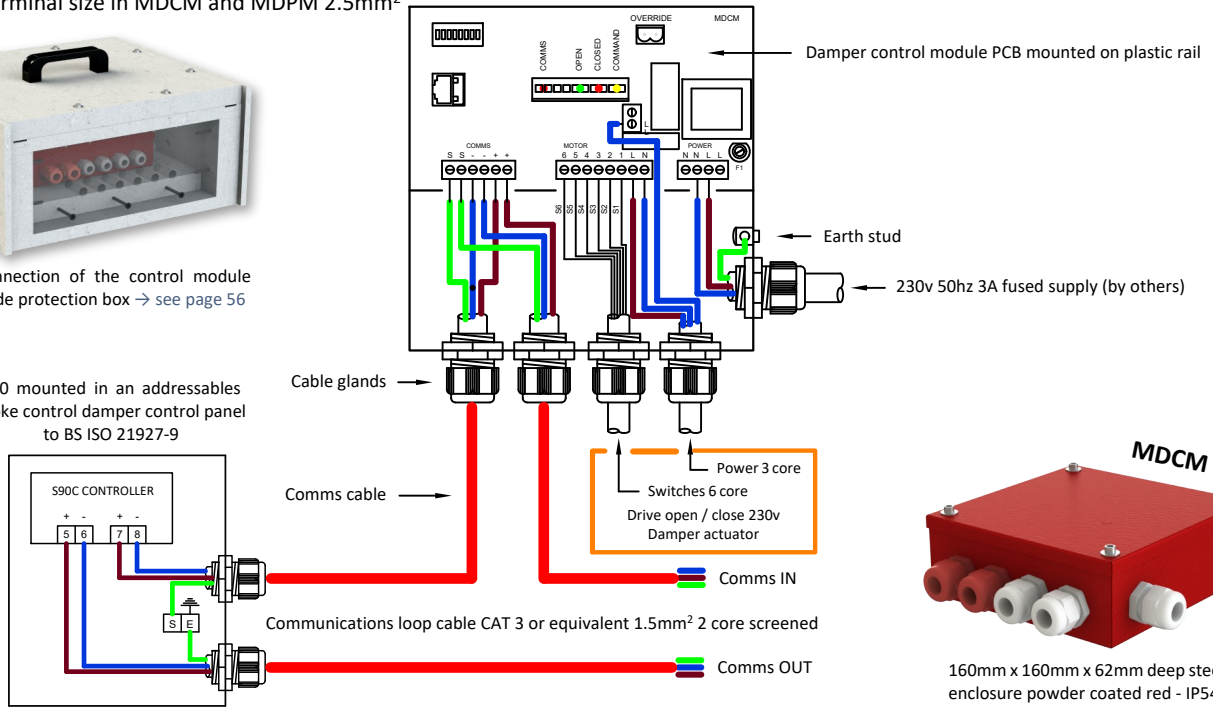

### Communication and control module MDPM

- The MDPM damper control module is a combined control module and damper positioning module to provide a balanced/3R position.
- It is connected on a bi directional communication loop back to a control panel.
- Max terminal size in MDCM and MDPM 2.5mm<sup>2</sup>
- Each MDPM has a 230v local spur for powering the damper actuator, located at the FCC.
- Up to 96x MDPM's can be connected on one loop and multiple loops can be incorporated.
- With an MA or AA system the MDPM's are mounted in a fire rated and tested Ca-Si housing to BS EN1366-10.

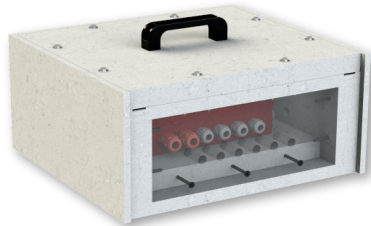

Details of connection of the control module interfaces inside protection box → see page 56

S90 mounted in an addressable smoke control damper control panel to BS ISO 21927-9

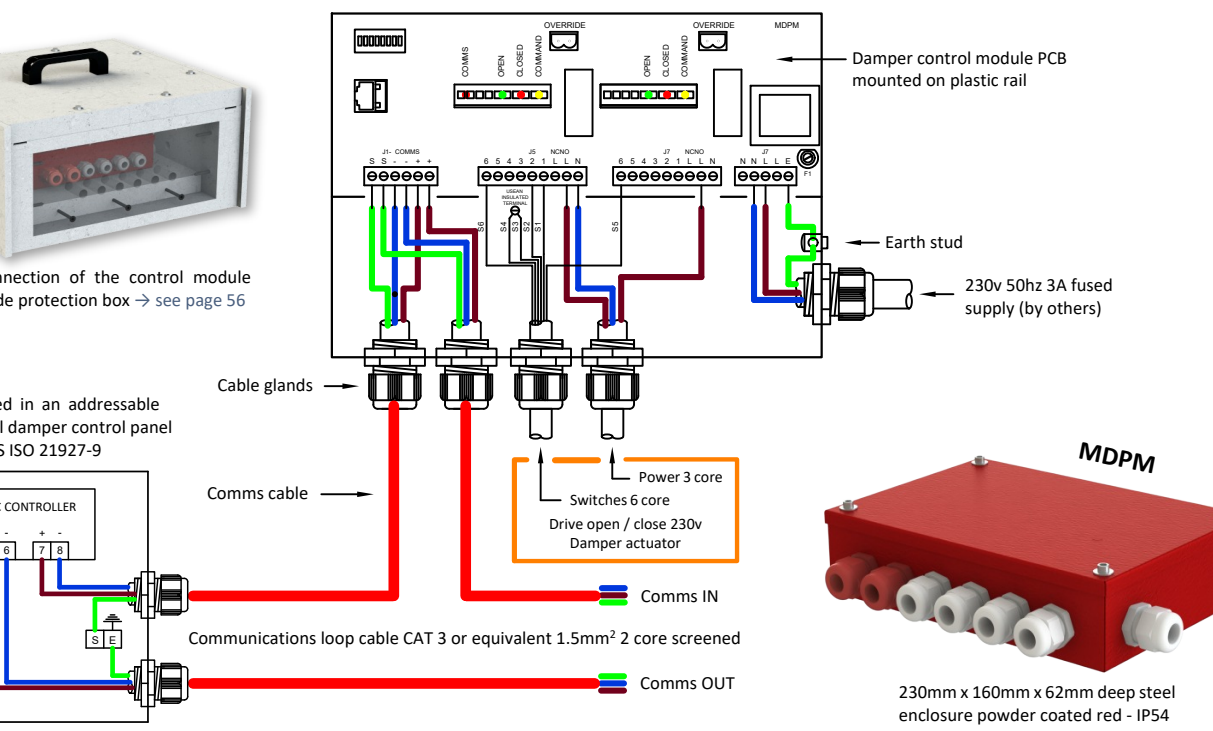

### III. DIMENSIONS

#### SEDM without flange

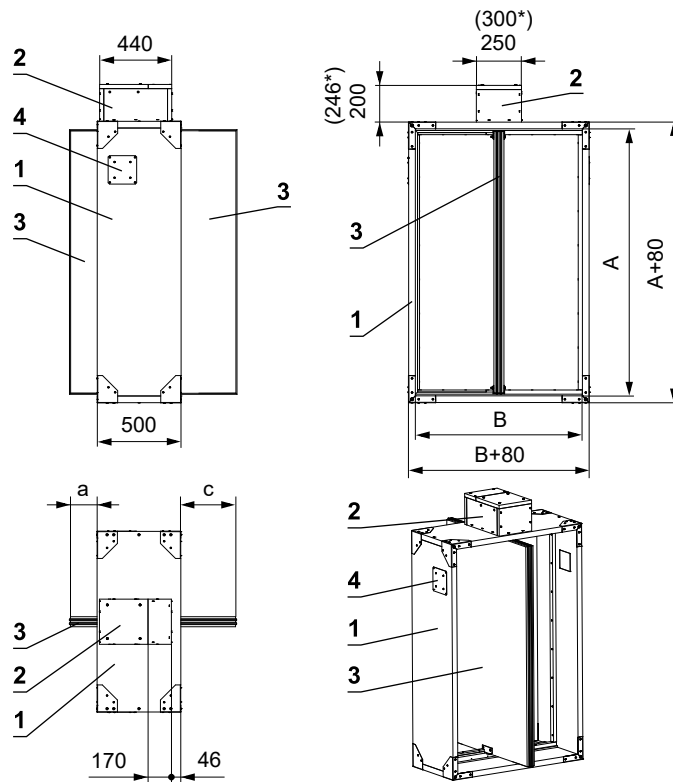

#### SEDM with flange

■ External dimensions of flange A(B) + 60 is not same as external dimensions of damper

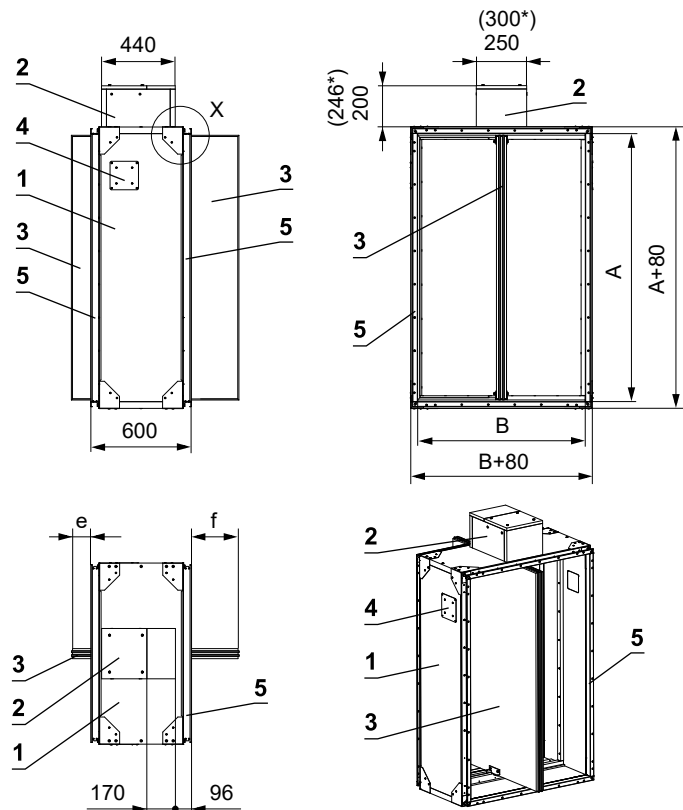
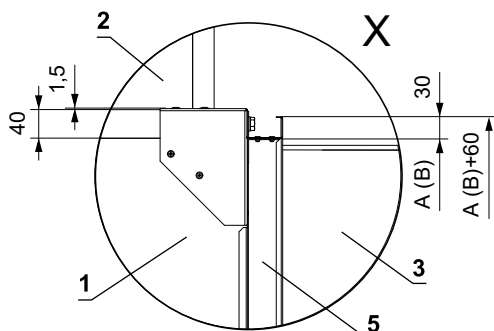

- 1 SEDM
- 2 Actuating mechanism
- 3 Damper blade
- 4 Inspection opening cover
- 5 Flange\*\*

\* Dimensions with actuating mechanism InMax 50.75S.  
 \*\* If it is necessary, arbitrary flange could be removed.

**Damper blade overlaps**

- For damper without flanges the open damper blade overlaps the damper body from dimension B = 250 by the value "c" or "a" and "c". These values are specified in chapter Technical parameters → see pages 12 to 23.
- For damper with flanges the open damper blade overlaps the damper body from dimension B = 355 by the value "f" or "e" and "f". These values are specified in chapter Technical parameters → see pages 12 to 23.

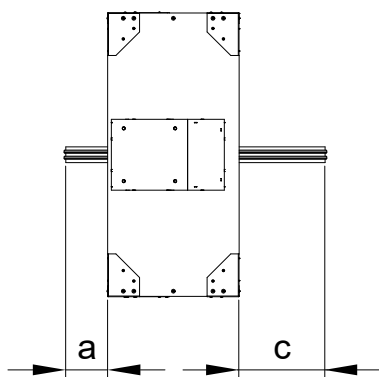
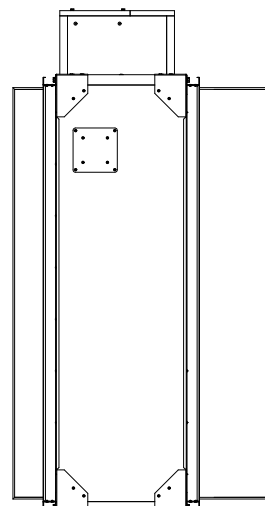
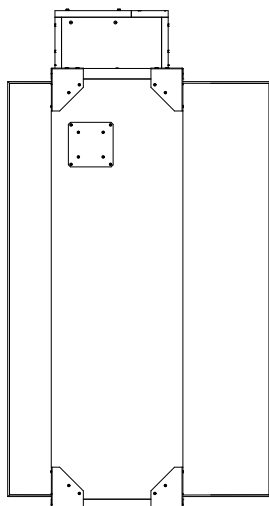

Values "a" and "c" - without flange

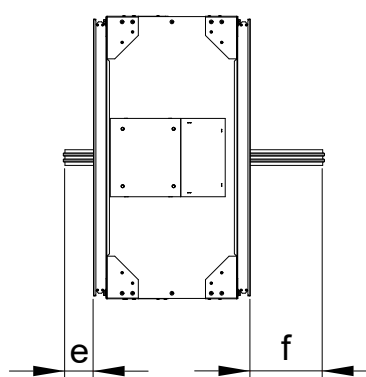

Values "e" and "f" - with flange

Values "a", "c", "e" and "f", has to be respected when projecting related smoke exhaust ducts.

**Flange with corner hole**

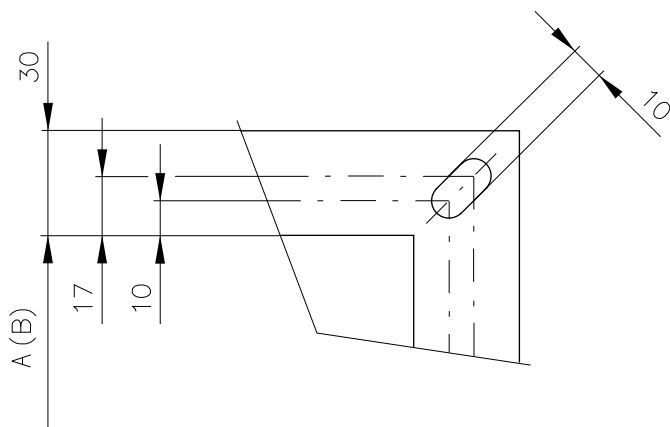

Flanges of dampers are 30 mm wide with oval hole.

Technical parameters

A x B [mm]	Damper blade overlaps without flanges		Damper blade overlaps with flanges		Weight [kg]		Effective area S <sub>ef</sub> [m <sup>2</sup> ]	Actuating mechanism type	
	a [mm]	c [mm]	e [mm]	f [mm]	Without flanges	With flanges			
180 x	180	-	-	-	-	38,3	41,4	0,0077	BELIMO BEN (15 N.m)
	200	-	-	-	-	39,6	42,8	0,0099	
	225	-	-	-	-	41,2	44,4	0,0127	
	250	-	-	-	-	42,8	46,2	0,0154	
	280	-	-	-	-	44,6	48,2	0,0187	
	300	-	-	-	-	45,9	49,5	0,0209	
	315	-	-	-	-	46,8	50,6	0,0226	
	355	-	6,5	-	-	49,3	53,3	0,0270	
	400	-	29	-	-	52,1	56,4	0,0319	
	450	-	54	-	4	55,2	59,8	0,0374	
	500	-	79	-	29	58,3	63,2	0,0429	
	550	-	104	-	54	61,4	66,6	0,0484	
	560	-	109	-	59	62,1	67,2	0,0495	
	600	-	129	-	79	64,7	69,9	0,0539	
	630	-	144	-	94	66,6	72,1	0,0572	
	650	-	154	-	104	67,8	73,4	0,0594	
	700	11	179	-	129	70,9	76,8	0,0649	
	710	16	184	-	134	71,6	77,5	0,0660	
	750	36	204	-	154	74,0	80,2	0,0704	
	800	61	229	11	179	77,1	83,6	0,0759	
900	111	279	61	229	83,4	90,5	0,0869		
1000	161	329	111	279	89,6	97,2	0,0979		
180	-	-	-	-	39,6	42,7	0,0091	BELIMO BEN (15 N.m)	
200	-	-	-	-	40,9	44,1	0,0117		
225	-	-	-	-	42,4	45,8	0,0150		
250	-	-	-	-	44,0	47,5	0,0182		
280	-	-	-	-	45,9	49,7	0,0221		
300	-	-	-	-	47,3	51,0	0,0247		
315	-	-	-	-	48,2	52,1	0,0267		
355	-	6,5	-	-	50,8	54,8	0,0319		
400	-	29	-	-	53,6	58,1	0,0377		
450	-	54	-	4	56,8	61,4	0,0442		
500	-	79	-	29	60,1	64,9	0,0507		
550	-	104	-	54	63,2	68,4	0,0572		
560	-	109	-	59	63,9	69,1	0,0585		
600	-	129	-	79	66,4	72,0	0,0637		
630	-	144	-	94	68,3	74,0	0,0676		
650	-	154	-	104	69,7	75,3	0,0702		
700	11	179	-	129	72,8	78,8	0,0767		
710	16	184	-	134	73,4	79,5	0,0780		
750	36	204	-	154	76,0	82,4	0,0832		BELIMO BEE (25 N.m)
800	61	229	11	179	79,2	85,9	0,0897		
900	111	279	61	229	85,6	92,7	0,1027		
1000	161	329	111	279	91,9	99,8	0,1157		
225 x	180	-	-	-	-	41,0	44,4	0,0109	BELIMO BEN (15 N.m)
	200	-	-	-	-	42,4	45,8	0,0140	
	225	-	-	-	-	44,0	47,5	0,0178	
	250	-	-	-	-	45,6	49,3	0,0217	
	280	-	-	-	-	47,7	51,4	0,0264	
	300	-	-	-	-	49,0	52,9	0,0295	
	315	-	-	-	-	50,0	54,0	0,0318	
	355	-	6,5	-	-	52,5	56,8	0,0380	

Sizes listed within the maximum/minimum sizes can be manufactured on request.

A x B [mm]	Damper blade overlaps without flanges		Damper blade overlaps with flanges		Weight [kg]		Effective area $S_{ef}$ [m <sup>2</sup> ]	Actuating mechanism type		
	a [mm]	c [mm]	e [mm]	f [mm]	Without flanges	With flanges				
225 x	400	-	29	-	-	55,5	60,1	0,0450	BELIMO BEN (15 N.m)	
	450	-	54	-	4	58,9	63,6	0,0527		
	500	-	79	-	29	62,1	67,2	0,0605		
	550	-	104	-	54	65,3	70,7	0,0682		
	560	-	109	-	59	66,0	71,4	0,0698		
	600	-	129	-	79	68,7	74,3	0,0760		
	630	-	144	-	94	70,6	76,4	0,0806		
	650	-	154	-	104	72,0	77,9	0,0837		
	700	11	179	-	129	75,2	81,4	0,0915		
	710	16	184	-	134	75,9	82,1	0,0930		
	750	36	204	-	154	78,6	85,1	0,0992		
	800	61	229	11	179	81,8	88,6	0,1070		BELIMO BEE (25 N.m)
	900	111	279	61	229	88,4	95,7	0,1225		
1000	161	329	111	279	94,9	102,9	0,1380			
250 x	180	-	-	-	-	42,5	46,0	0,0126	BELIMO BEN (15 N.m)	
	200	-	-	-	-	43,9	47,5	0,0162		
	225	-	-	-	-	45,6	49,3	0,0207		
	250	-	-	-	-	47,3	51,2	0,0252		
	280	-	-	-	-	49,3	53,3	0,0306		
	300	-	-	-	-	50,6	54,8	0,0342		
	315	-	-	-	-	51,7	55,9	0,0369		
	355	-	6,5	-	-	54,4	58,7	0,0441		
	400	-	29	-	-	57,4	62,1	0,0522		
	450	-	54	-	4	60,8	65,7	0,0612		
	500	-	79	-	29	64,1	69,4	0,0702		
	550	-	104	-	54	67,5	73,0	0,0792		
	560	-	109	-	59	68,2	73,7	0,0810		
	600	-	129	-	79	70,9	76,7	0,0882		
	630	-	144	-	94	72,9	78,8	0,0936		
	650	-	154	-	104	74,3	80,3	0,0972		
	700	11	179	-	129	77,6	84,0	0,1062		
	710	16	184	-	134	78,3	84,8	0,1080		
	750	36	204	-	154	81,0	87,6	0,1152		BELIMO BEE (25 N.m)
800	61	229	11	179	84,4	91,3	0,1242			
900	111	279	61	229	91,1	98,6	0,1422			
1000	161	329	111	279	97,9	105,8	0,1602			
280 x	180	-	-	-	-	42,8	46,2	0,0147	BELIMO BEN (15 N.m)	
	200	-	-	-	-	44,1	47,7	0,0189		
	225	-	-	-	-	45,8	49,4	0,0242		
	250	-	-	-	-	47,5	51,2	0,0294		
	280	-	-	-	-	49,4	53,4	0,0357		
	300	-	-	-	-	50,8	54,9	0,0399		
	315	-	-	-	-	51,7	56,0	0,0431		
	355	-	6,5	-	-	54,5	58,9	0,0515		
	400	-	29	-	-	57,5	62,1	0,0609		
	450	-	54	-	4	60,8	65,8	0,0714		
	500	-	79	-	29	64,2	69,4	0,0819		
	550	-	104	-	54	67,5	72,9	0,0924		
	560	-	109	-	59	68,3	73,7	0,0945		
	600	-	129	-	79	70,9	76,6	0,1029		
630	-	144	-	94	72,9	78,8	0,1092			

Sizes listed within the maximum/minimum sizes can be manufactured on request.

A x B [mm]	Damper blade overlaps without flanges		Damper blade overlaps with flanges		Weight [kg]		Effective area S <sub>ef</sub> [m <sup>2</sup> ]	Actuating mechanism type	
	a [mm]	c [mm]	e [mm]	f [mm]	Without flanges	With flanges			
280 x	650	-	154	-	104	74,2	80,2	0,1134	BELIMO BEN (15 N.m)
	700	11	179	-	129	77,6	83,9	0,1239	
	710	16	184	-	134	78,3	84,6	0,1260	
	750	36	204	-	154	80,9	87,5	0,1344	
	800	61	229	11	179	84,2	91,1	0,1449	
	900	111	279	61	229	91,0	98,3	0,1659	
	1000	161	329	111	279	97,6	105,6	0,1869	
300 x	180	-	-	-	-	43,9	47,5	0,0161	BELIMO BEN (15 N.m)
	200	-	-	-	-	45,2	49,0	0,0207	
	225	-	-	-	-	46,9	50,8	0,0265	
	250	-	-	-	-	48,8	52,7	0,0322	
	280	-	-	-	-	50,7	54,9	0,0391	
	300	-	-	-	-	52,1	56,3	0,0437	
	315	-	-	-	-	53,2	57,5	0,0472	
	355	-	6,5	-	-	55,9	60,3	0,0564	
	400	-	29	-	-	58,9	63,7	0,0667	
	450	-	54	-	4	62,4	67,3	0,0782	
	500	-	79	-	29	65,8	71,1	0,0897	
	550	-	104	-	54	69,2	74,8	0,1012	
	560	-	109	-	59	69,8	75,5	0,1035	
	600	-	129	-	79	72,5	78,4	0,1127	
	630	-	144	-	94	74,6	80,6	0,1196	
	650	-	154	-	104	76,1	82,2	0,1242	
	700	11	179	-	129	79,4	85,8	0,1357	
	710	16	184	-	134	80,1	86,6	0,1380	
	750	36	204	-	154	82,8	89,4	0,1472	
	800	61	229	11	179	86,3	93,2	0,1587	
900	111	279	61	229	93,1	100,6	0,1817		
1000	161	329	111	279	100,0	107,9	0,2047		
315 x	180	-	-	-	-	44,7	48,5	0,0172	BELIMO BEN (15 N.m)
	200	-	-	-	-	46,2	49,9	0,0221	
	225	-	-	-	-	47,8	51,7	0,0282	
	250	-	-	-	-	49,7	53,7	0,0343	
	280	-	-	-	-	51,7	55,9	0,0417	
	300	-	-	-	-	53,0	57,5	0,0466	
	315	-	-	-	-	54,1	58,5	0,0502	
	355	-	6,5	-	-	56,9	61,5	0,0600	
	400	-	29	-	-	60,1	64,9	0,0711	
	450	-	54	-	4	63,4	68,6	0,0833	
	500	-	79	-	29	67,0	72,4	0,0956	
	550	-	104	-	54	70,5	76,1	0,1078	
	560	-	109	-	59	71,1	76,8	0,1103	
	600	-	129	-	79	73,8	79,8	0,1201	
	630	-	144	-	94	75,9	82,0	0,1274	
	650	-	154	-	104	77,4	83,6	0,1323	
	700	11	179	-	129	80,9	87,4	0,1446	
	710	16	184	-	134	81,5	88,0	0,1470	
	750	36	204	-	154	84,2	91,0	0,1568	
	800	61	229	11	179	87,8	94,8	0,1691	
900	111	279	61	229	94,6	102,3	0,1936		
1000	161	329	111	279	101,7	109,7	0,2181		

Sizes listed within the maximum/minimum sizes can be manufactured on request.

A x B [mm]	Damper blade overlaps without flanges		Damper blade overlaps with flanges		Weight [kg]		Effective area $S_{ef}$ [m <sup>2</sup> ]	Actuating mechanism type	
	a [mm]	c [mm]	e [mm]	f [mm]	Without flanges	With flanges			
355 x	180	-	-	-	-	46,3	50,2	0,0200	BELIMO BEN (15 N.m)
	200	-	-	-	-	47,7	51,7	0,0257	
	225	-	-	-	-	49,5	53,6	0,0328	
	250	-	-	-	-	51,3	55,6	0,0399	
	280	-	-	-	-	53,5	57,9	0,0485	
	300	-	-	-	-	54,9	59,4	0,0542	
	315	-	-	-	-	55,9	60,5	0,0584	
	355	-	6,5	-	-	58,8	63,5	0,0698	
	400	-	29	-	-	62,0	66,9	0,0827	
	450	-	54	-	4	65,5	70,8	0,0969	
	500	-	79	-	29	69,1	74,6	0,1112	
	550	-	104	-	54	72,6	78,5	0,1254	
	560	-	109	-	59	73,3	79,2	0,1283	
	600	-	129	-	79	76,2	82,2	0,1397	
	630	-	144	-	94	78,3	84,5	0,1482	
	650	-	154	-	104	79,7	86,0	0,1539	
	700	11	179	-	129	83,3	89,9	0,1682	
	710	16	184	-	134	84,0	90,6	0,1710	
	750	36	204	-	154	86,8	93,7	0,1824	
	800	61	229	11	179	90,4	97,5	0,1967	
900	111	279	61	229	97,4	105,1	0,2252		
1000	161	329	111	279	104,6	112,8	0,2537		
180	-	-	-	-	49,7	53,8	0,0231	BELIMO BEN (15 N.m)	
200	-	-	-	-	51,2	55,5	0,0297		
225	-	-	-	-	53,0	57,5	0,0380		
250	-	-	-	-	55,0	59,5	0,0462		
280	-	-	-	-	57,2	61,9	0,0561		
300	-	-	-	-	58,8	63,4	0,0627		
315	-	-	-	-	59,8	64,7	0,0677		
355	-	6,5	-	-	62,9	68,0	0,0809		
400	-	29	-	-	66,2	71,5	0,0957		
450	-	54	-	4	69,9	75,5	0,1122		
500	-	79	-	29	73,7	79,6	0,1287		
550	-	104	-	54	77,5	83,6	0,1452		
560	-	109	-	59	78,3	84,4	0,1485		
600	-	129	-	79	81,3	87,6	0,1617		
630	-	144	-	94	83,5	90,1	0,1716		
650	-	154	-	104	85,0	91,7	0,1782		
700	11	179	-	129	88,8	95,7	0,1947		
710	16	184	-	134	89,6	96,5	0,1980		
750	36	204	-	154	92,6	99,7	0,2112		
800	61	229	11	179	96,3	103,7	0,2277		BELIMO BEE (25 N.m)
900	111	279	61	229	103,7	111,8	0,2607		
1000	161	329	111	279	111,3	119,9	0,2937		
180	-	-	-	-	52,7	57,1	0,0266	BELIMO BEN (15 N.m)	
200	-	-	-	-	54,2	58,8	0,0342		
225	-	-	-	-	56,2	60,8	0,0437		
250	-	-	-	-	58,1	62,9	0,0532		
280	-	-	-	-	60,5	65,4	0,0646		
300	-	-	-	-	62,0	67,1	0,0722		
315	-	-	-	-	63,2	68,4	0,0779		

Sizes listed within the maximum/minimum sizes can be manufactured on request.

A x B [mm]	Damper blade overlaps without flanges		Damper blade overlaps with flanges		Weight [kg]		Effective area S <sub>ef</sub> [m <sup>2</sup> ]	Actuating mechanism type		
	a [mm]	c [mm]	e [mm]	f [mm]	Without flanges	With flanges				
450 x	355	-	6,5	-	-	66,3	71,8	0,0931	BELIMO BEN (15 N.m)	
	400	-	29	-	-	69,9	75,5	0,1102		
	450	-	54	-	4	73,8	79,7	0,1292		
	500	-	79	-	29	77,7	83,9	0,1482		
	550	-	104	-	54	81,6	88,0	0,1672		
	560	-	109	-	59	82,4	88,9	0,1710		
	600	-	129	-	79	85,5	92,3	0,1862		
	630	-	144	-	94	87,9	94,8	0,1976		
	650	-	154	-	104	89,4	96,5	0,2052		
	700	11	179	-	129	93,5	100,6	0,2242		
	710	16	184	-	134	94,3	101,5	0,2280		
	750	36	204	-	154	97,4	104,8	0,2432		
	800	61	229	11	179	101,3	109,1	0,2622		BELIMO BEE (25 N.m)
	900	111	279	61	229	109,1	117,4	0,3002		
1000	161	329	111	279	118,3	127,1	0,3382			
180	-	-	-	-	53,4	56,9	0,0301	BELIMO BEN (15 N.m)		
200	-	-	-	-	55,0	58,7	0,0387			
225	-	-	-	-	56,9	60,6	0,0495			
250	-	-	-	-	58,9	62,7	0,0602			
280	-	-	-	-	61,3	65,2	0,0731			
300	-	-	-	-	62,9	66,9	0,0817			
315	-	-	-	-	64,0	68,1	0,0882			
355	-	6,5	-	-	67,1	71,5	0,1054			
400	-	29	-	-	70,8	75,2	0,1247			
450	-	54	-	4	74,6	79,2	0,1462			
500	-	79	-	29	78,6	83,4	0,1677			
550	-	104	-	54	82,5	87,5	0,1892			
560	-	109	-	59	83,3	88,3	0,1935			
600	-	129	-	79	86,5	91,6	0,2107			
630	-	144	-	94	88,8	94,1	0,2236			
650	-	154	-	104	90,4	95,8	0,2322			
700	11	179	-	129	94,4	99,9	0,2537			
710	16	184	-	134	95,1	100,7	0,2580			
750	36	204	-	154	98,3	104,1	0,2752		BELIMO BEE (25 N.m)	
800	61	229	11	179	102,3	108,1	0,2967			
900	111	279	61	229	110,0	116,4	0,3397			
1000	161	329	111	279	119,3	126	0,3827			
550 x	180	-	-	-	-	56,1	61,0	0,0336	BELIMO BEN (15 N.m)	
	200	-	-	-	-	57,9	62,8	0,0432		
	225	-	-	-	-	59,9	64,9	0,0552		
	250	-	-	-	-	61,9	67,0	0,0672		
	280	-	-	-	-	64,4	69,6	0,0816		
	300	-	-	-	-	66,0	71,4	0,0912		
	315	-	-	-	-	67,3	72,8	0,0984		
	355	-	6,5	-	-	70,5	76,3	0,1176		
	400	-	29	-	-	74,3	80,1	0,1392		
	450	-	54	-	4	78,3	84,5	0,1632		
	500	-	79	-	29	82,4	88,9	0,1872		
	550	-	104	-	54	86,5	93,3	0,2112		
	560	-	109	-	59	87,4	94,1	0,2160		
	600	-	129	-	79	90,6	97,5	0,2352		

Sizes listed within the maximum/minimum sizes can be manufactured on request.

A x B [mm]	Damper blade overlaps without flanges		Damper blade overlaps with flanges		Weight [kg]		Effective area $S_{ef}$ [m <sup>2</sup> ]	Actuating mechanism type	
	a [mm]	c [mm]	e [mm]	f [mm]	Without flanges	With flanges			
550 x	630	-	144	-	94	93,1	100,1	0,2496	BELIMO BEN (15 N.m)
	650	-	154	-	104	94,8	101,9	0,2592	
	700	11	179	-	129	98,8	106,3	0,2832	
	710	16	184	-	134	99,6	107,1	0,2880	
	750	36	204	-	154	102,9	110,6	0,3072	BELIMO BEE (25 N.m)
	800	61	229	11	179	107,0	115,0	0,3312	
	900	111	279	61	229	116,5	125,0	0,3792	
	1000	161	329	111	279	124,6	133,6	0,4272	
560 x	180	-	-	-	-	56,8	61,5	0,0343	BELIMO BEN (15 N.m)
	200	-	-	-	-	58,4	63,4	0,0441	
	225	-	-	-	-	60,5	65,5	0,0564	
	250	-	-	-	-	62,5	67,8	0,0686	
	280	-	-	-	-	65,0	70,4	0,0833	
	300	-	-	-	-	66,6	72,1	0,0931	
	315	-	-	-	-	67,9	73,4	0,1005	
	355	-	6,5	-	-	71,3	76,9	0,1201	
	400	-	29	-	-	74,9	80,9	0,1421	
	450	-	54	-	4	79,0	85,3	0,1666	
	500	-	79	-	29	83,1	89,6	0,1911	
	550	-	104	-	54	87,3	94,0	0,2156	
	560	-	109	-	59	88,1	94,9	0,2205	
	600	-	129	-	79	91,5	98,4	0,2401	
	630	-	144	-	94	93,9	101,1	0,2548	
	650	-	154	-	104	95,6	102,9	0,2646	
	700	11	179	-	129	99,8	107,3	0,2891	BELIMO BEE (25 N.m)
	710	16	184	-	134	100,5	108,1	0,2940	
	750	36	204	-	154	103,9	111,6	0,3136	
	800	61	229	11	179	108,0	116,0	0,3381	
900	111	279	61	229	117,5	126,0	0,3871	BELIMO BE (40 N.m)	
1000	161	329	111	279	125,8	134,9	0,4361		
180	-	-	-	-	59,0	64,0	0,0371		
200	-	-	-	-	60,6	65,9	0,0477		
225	-	-	-	-	62,8	68,1	0,0610		
250	-	-	-	-	65,0	70,4	0,0742		
280	-	-	-	-	67,5	73,0	0,0901		
300	-	-	-	-	69,3	74,9	0,1007		
315	-	-	-	-	70,5	76,3	0,1087		
355	-	6,5	-	-	73,9	79,9	0,1299		
400	-	29	-	-	77,8	83,9	0,1537	BELIMO BEN (15 N.m)	
450	-	54	-	4	82,0	88,4	0,1802		
500	-	79	-	29	86,3	92,9	0,2067		
550	-	104	-	54	90,5	97,5	0,2332		
560	-	109	-	59	91,4	98,4	0,2385		
600	-	129	-	79	94,8	102,0	0,2597		
630	-	144	-	94	97,4	104,8	0,2756		
650	-	154	-	104	99,0	106,5	0,2862		
700	11	179	-	129	103,3	111,0	0,3127		
710	16	184	-	134	104,1	111,9	0,3180		
750	36	204	-	154	107,5	115,5	0,3392		BELIMO BEE (25 N.m)
800	61	229	11	179	111,8	120,0	0,3657		
900	111	279	61	229	121,6	130,4	0,4187		

Sizes listed within the maximum/minimum sizes can be manufactured on request.

A x B [mm]	Damper blade overlaps without flanges		Damper blade overlaps with flanges		Weight [kg]		Effective area S <sub>ef</sub> [m <sup>2</sup> ]	Actuating mechanism type		
	a [mm]	c [mm]	e [mm]	f [mm]	Without flanges	With flanges				
600 x 1000	161	329	111	279	130,1	139,4	0,4717	BELIMO BE (40 N.m)		
180	-	-	-	-	60,6	65,9	0,0392			
200	-	-	-	-	62,4	67,6	0,0504			
225	-	-	-	-	64,6	70,0	0,0644			
250	-	-	-	-	66,8	72,3	0,0784			
280	-	-	-	-	69,4	75,1	0,0952			
300	-	-	-	-	71,1	76,9	0,1064			
315	-	-	-	-	72,4	78,3	0,1148			
355	-	6,5	-	-	75,9	82,0	0,1372			
400	-	29	-	-	79,9	86,1	0,1624		BELIMO BEN (15 N.m)	
450	-	54	-	4	84,1	90,8	0,1904			
500	-	79	-	29	88,5	95,4	0,2184			
550	-	104	-	54	92,9	100,0	0,2464			
560	-	109	-	59	93,8	100,9	0,2520			
600	-	129	-	79	97,3	104,6	0,2744			
630	-	144	-	94	99,9	107,4	0,2912			
650	-	154	-	104	101,6	109,3	0,3024			
700	11	179	-	129	106,0	113,9	0,3304			
710	16	184	-	134	106,9	114,8	0,3360	BELIMO BEE (25 N.m)		
750	36	204	-	154	110,4	118,5	0,3584			
800	61	229	11	179	114,8	123,1	0,3864			
900	111	279	61	229	124,6	133,6	0,4424			
1000	161	329	111	279	133,4	142,9	0,4984		BELIMO BE (40 N.m)	
180	-	-	-	-	61,8	67,1	0,0406			
200	-	-	-	-	63,5	68,9	0,0522			
225	-	-	-	-	65,8	71,3	0,0667			
250	-	-	-	-	68,0	73,6	0,0812			
280	-	-	-	-	70,6	76,4	0,0986			
300	-	-	-	-	72,4	78,3	0,1102			
315	-	-	-	-	73,8	79,8	0,1189			
355	-	6,5	-	-	77,3	83,5	0,1421			
400	-	29	-	-	81,3	87,6	0,1682	BELIMO BEN (15 N.m)		
450	-	54	-	4	85,6	92,4	0,1972			
500	-	79	-	29	90,1	97,0	0,2262			
550	-	104	-	54	94,5	101,8	0,2552			
560	-	109	-	59	95,4	102,6	0,2610			
600	-	129	-	79	98,9	106,4	0,2842			
630	-	144	-	94	101,6	109,3	0,3016			
650	-	154	-	104	103,4	111,1	0,3132			
700	11	179	-	129	107,8	115,8	0,3422			
710	16	184	-	134	108,6	116,8	0,3480		BELIMO BEE (25 N.m)	
750	36	204	-	154	112,3	120,5	0,3712			
800	61	229	11	179	117,9	126,4	0,4002			
900	111	279	61	229	126,8	135,8	0,4582	BELIMO BE (40 N.m)		
1000	161	329	111	279	135,6	145,1	0,5162			
180	-	-	-	-	64,5	66,2	0,0441			
200	-	-	-	-	66,4	68,0	0,0567			
225	-	-	-	-	68,8	70,3	0,0725			BELIMO BEN (15 N.m)
250	-	-	-	-	71,0	72,6	0,0882			
280	-	-	-	-	73,8	75,4	0,1071			
300	-	-	-	-	75,6	77,2	0,1197			

Sizes listed within the maximum/minimum sizes can be manufactured on request.

A x B [mm]	Damper blade overlaps without flanges		Damper blade overlaps with flanges		Weight [kg]		Effective area $S_{ef}$ [m <sup>2</sup> ]	Actuating mechanism type	
	a [mm]	c [mm]	e [mm]	f [mm]	Without flanges	With flanges			
700 x	315	-	-	-	77,0	78,6	0,1292	BELIMO BEN (15 N.m)	
	355	-	6,5	-	80,6	82,2	0,1544		
	400	-	29	-	84,8	86,4	0,1827		
	450	-	54	-	89,4	90,9	0,2142		
	500	-	79	-	93,9	95,5	0,2457		
	550	-	104	-	98,5	100,1	0,2772		
	560	-	109	-	99,4	101,0	0,2835		
	600	-	129	-	103,1	104,7	0,3087		
	630	-	144	-	105,9	107,4	0,3276		
	650	-	154	-	107,6	109,2	0,3402		
	700	11	179	-	129	112,3	113,8		0,3717
	710	16	184	-	134	113,1	114,7		0,3780
	750	36	204	-	154	116,9	118,4		0,4032
	800	61	229	11	179	122,8	124,1		0,4347
	900	111	279	61	229	131,9	133,2		0,4977
	1000	161	329	111	279	141,0	142,4		0,5607
710 x	180	-	-	-	63,6	69,1	0,0448	BELIMO BEN (15 N.m)	
	200	-	-	-	65,4	70,9	0,0576		
	225	-	-	-	67,6	73,3	0,0736		
	250	-	-	-	69,9	75,8	0,0896		
	280	-	-	-	72,6	78,6	0,1088		
	300	-	-	-	74,4	80,5	0,1216		
	315	-	-	-	75,8	81,9	0,1312		
	355	-	6,5	-	79,3	85,6	0,1568		
	400	-	29	-	83,4	90,0	0,1856		
	450	-	54	-	87,8	94,8	0,2176		
	500	-	79	-	92,4	99,6	0,2496		
	550	-	104	-	96,9	104,3	0,2816		
	560	-	109	-	97,8	105,2	0,2880		
	600	-	129	-	101,4	109,1	0,3136		
	630	-	144	-	102,4	111,9	0,3328		
	650	-	154	-	104,2	113,8	0,3456		
700	11	179	-	129	108,6	118,6	0,3776		
710	16	184	-	134	109,6	119,6	0,3840		
750	36	204	-	154	113,0	123,3	0,4096		
800	61	229	11	179	118,7	129,3	0,4416		
900	111	279	61	229	127,6	138,8	0,5056		
1000	161	329	111	279	136,4	148,4	0,5696		
750 x	180	-	-	-	64,7	70,2	0,0476	BELIMO BEN (15 N.m)	
	200	-	-	-	66,5	72,1	0,0612		
	225	-	-	-	68,8	74,6	0,0782		
	250	-	-	-	71,0	77,0	0,0952		
	280	-	-	-	73,8	79,9	0,1156		
	300	-	-	-	75,6	81,8	0,1292		
	315	-	-	-	76,9	83,3	0,1394		
	355	-	6,5	-	80,6	87,1	0,1666		
	400	-	29	-	84,7	91,4	0,1972		
	450	-	54	-	89,3	96,2	0,2312		
	500	-	79	-	93,8	101,0	0,2652		
	550	-	104	-	98,4	105,8	0,2992		
560	-	109	-	99,4	106,8	0,3060			

Sizes listed within the maximum/minimum sizes can be manufactured on request.

A x B [mm]	Damper blade overlaps without flanges		Damper blade overlaps with flanges		Weight [kg]		Effective area S <sub>ef</sub> [m <sup>2</sup> ]	Actuating mechanism type	
	a [mm]	c [mm]	e [mm]	f [mm]	Without flanges	With flanges			
750 x	600	-	129	-	79	103,0	110,6	0,3332	BELIMO BEN (15 N.m)
	630	-	144	-	94	105,7	113,5	0,3536	
	650	-	154	-	104	107,5	115,4	0,3672	
	700	11	179	-	129	112,1	120,2	0,4012	BELIMO BEE (25 N.m)
	710	16	184	-	134	113,0	121,2	0,4080	
	750	36	204	-	154	117,8	126,2	0,4352	
	800	61	229	11	179	122,4	131,0	0,4692	BELIMO BE (40 N.m)
	900	111	279	61	229	131,5	140,8	0,5372	
	1000	161	329	111	279	143,0	152,9	0,6052	
800 x	180	-	-	-	-	68,4	74,4	0,0511	BELIMO BEN (15 N.m)
	200	-	-	-	-	70,4	76,4	0,0657	
	225	-	-	-	-	72,8	78,9	0,0840	
	250	-	-	-	-	75,2	81,5	0,1022	
	280	-	-	-	-	78,1	84,5	0,1241	
	300	-	-	-	-	79,9	86,5	0,1387	
	315	-	-	-	-	81,4	88,1	0,1497	
	355	-	6,5	-	-	85,3	92,1	0,1789	
	400	-	29	-	-	89,5	96,6	0,2117	
	450	-	54	-	4	94,3	101,6	0,2482	
	500	-	79	-	29	99,2	106,8	0,2847	
	550	-	104	-	54	103,9	111,8	0,3212	
	560	-	109	-	59	104,9	112,7	0,3285	
	600	-	129	-	79	108,7	116,8	0,3577	
	630	-	144	-	94	111,6	119,8	0,3796	
	650	-	154	-	104	113,6	121,9	0,3942	
	700	11	179	-	129	118,3	126,9	0,4307	
	710	16	184	-	134	119,3	127,9	0,4380	
	750	36	204	-	154	124,3	133,2	0,4672	
800	61	229	11	179	129,2	138,2	0,5037		
900	111	279	61	229	138,7	148,4	0,5767		
1000	161	329	111	279	148,4	158,5	0,6497		
900 x	180	-	-	-	-	72,7	72,5	0,0581	BELIMO BEN (15 N.m)
	200	-	-	-	-	74,8	81,1	0,0747	
	225	-	-	-	-	77,3	83,8	0,0955	
	250	-	-	-	-	79,8	86,4	0,1162	
	280	-	-	-	-	82,8	89,6	0,1411	
	300	-	-	-	-	84,7	91,7	0,1577	
	315	-	-	-	-	86,3	93,4	0,1702	
	355	-	6,5	-	-	90,2	97,6	0,2034	
	400	-	29	-	-	94,8	102,2	0,2407	
	450	-	54	-	4	99,8	107,5	0,2822	
	500	-	79	-	29	104,9	112,8	0,3237	
	550	-	104	-	54	109,9	118,1	0,3652	
	560	-	109	-	59	110,9	119,2	0,3735	
	600	-	129	-	79	115,0	123,4	0,4067	
	630	-	144	-	94	118,0	126,6	0,4316	
	650	-	154	-	104	120,0	128,6	0,4482	
	700	11	179	-	129	126,2	135,1	0,4897	
	710	16	184	-	134	127,2	136,2	0,4980	
	750	36	204	-	154	131,3	140,4	0,5312	
800	61	229	11	179	136,3	145,7	0,5727		

Sizes listed within the maximum/minimum sizes can be manufactured on request.

A x B [mm]	Damper blade overlaps without flanges		Damper blade overlaps with flanges		Weight [kg]		Effective area S <sub>ef</sub> [m <sup>2</sup> ]	Actuating mechanism type	
	a [mm]	c [mm]	e [mm]	f [mm]	Without flanges	With flanges			
900 x	900	111	279	61	229	146,3	156,2	0,6557	BELIMO BE (40 N.m)
	1000	161	329	111	279	156,4	166,8	0,7387	
	180	-	-	-	-	78,1	83,5	0,0651	
	200	-	-	-	-	80,2	85,7	0,0837	
	225	-	-	-	-	82,9	88,5	0,1070	
	250	-	-	-	-	85,6	91,2	0,1302	
	280	-	-	-	-	88,8	94,5	0,1581	
	300	-	-	-	-	90,8	96,8	0,1767	
	315	-	-	-	-	92,5	98,4	0,1907	
	355	-	6,5	-	-	96,7	102,8	0,2279	
1000 x	400	-	29	-	-	101,5	107,7	0,2697	BELIMO BEN (15 N.m)
	450	-	54	-	4	106,9	113,2	0,3162	
	500	-	79	-	29	112,2	118,7	0,3627	
	550	-	104	-	54	117,6	124,1	0,4092	
	560	-	109	-	59	118,7	125,3	0,4185	
	600	-	129	-	79	122,9	129,7	0,4557	
	630	-	144	-	94	126,1	133,0	0,4836	
	650	-	154	-	104	129,5	136,4	0,5022	
	700	11	179	-	129	134,8	141,8	0,5487	
	710	16	184	-	134	135,8	143,0	0,5580	
1000 x	750	36	204	-	154	140,2	147,4	0,5952	BELIMO BE (40 N.m)
	800	61	229	11	179	145,4	152,8	0,6417	
	900	111	279	61	229	156,1	163,9	0,7347	
	1000	161	329	111	279	166,8	174,9	0,8277	
	180	-	-	-	-	83,4	87,1	0,0721	
	200	-	-	-	-	85,7	89,2	0,0927	
	225	-	-	-	-	88,6	92,1	0,1185	
	250	-	-	-	-	91,3	95,0	0,1442	
	280	-	-	-	-	94,7	98,3	0,1751	
	300	-	-	-	-	97,0	100,6	0,1957	
1100 x	315	-	-	-	-	98,6	102,2	0,2112	BELIMO BEN (15 N.m)
	355	-	6,5	-	-	103,2	106,8	0,2524	
	400	-	29	-	-	108,2	111,9	0,2987	
	450	-	54	-	4	114,0	117,5	0,3502	
	500	-	79	-	29	119,6	123,2	0,4017	
	550	-	104	-	54	125,3	128,9	0,4532	
	560	-	109	-	59	126,4	130,0	0,4635	
	600	-	129	-	79	130,9	134,6	0,5047	
	630	-	144	-	94	135,5	139,0	0,5356	
	650	-	154	-	104	137,8	141,3	0,5562	
1100 x	700	11	179	-	129	143,4	147,0	0,6077	BELIMO BEE (25 N.m)
	710	16	184	-	134	144,6	148,1	0,6180	
	750	36	204	-	154	149,0	152,6	0,6592	
	800	61	229	11	179	154,7	158,4	0,7107	
	900	111	279	61	229	166,1	169,6	0,8137	
	1000	161	329	111	279	177,4	180,9	0,9167	
	180	-	-	-	-	91,4	97,9	0,0826	
	200	-	-	-	-	94,0	100,4	0,1062	
	225	-	-	-	-	97,0	103,6	0,1357	
	250	-	-	-	-	100,1	106,7	0,1652	
1250 x	280	-	-	-	-	103,7	110,4	0,2006	BELIMO BE (40 N.m)
	280	-	-	-	-	103,7	110,4	0,2006	
1250 x	225	-	-	-	-	97,0	103,6	0,1357	BELIMO BEN (15 N.m)
	250	-	-	-	-	100,1	106,7	0,1652	

Sizes listed within the maximum/minimum sizes can be manufactured on request.

A x B [mm]	Damper blade overlaps without flanges		Damper blade overlaps with flanges		Weight [kg]		Effective area S <sub>ef</sub> [m <sup>2</sup> ]	Actuating mechanism type	
	a [mm]	c [mm]	e [mm]	f [mm]	Without flanges	With flanges			
1250 x	300	-	-	-	106,2	113,0	0,2242	BELIMO BEN (15 N.m)	
	315	-	-	-	108,0	114,8	0,2419		
	355	-	6,5	-	-	112,9	119,9	0,2891	
	400	-	29	-	-	118,4	125,6	0,3422	
	450	-	54	-	4	124,6	131,8	0,4012	
	500	-	79	-	29	130,7	138,1	0,4602	
	550	-	104	-	54	136,8	144,3	0,5192	
	560	-	109	-	59	138,0	145,5	0,5310	
	600	-	129	-	79	144,1	151,7	0,5782	
	630	-	144	-	94	147,7	155,5	0,6136	
	650	-	154	-	104	150,2	158,0	0,6372	
	700	11	179	-	129	156,4	164,3	0,6962	BELIMO BE (40 N.m)
	710	16	184	-	134	157,6	165,6	0,7080	
	750	36	204	-	154	162,5	170,5	0,7552	
	800	61	229	11	179	168,6	176,8	0,8142	
	900	111	279	61	229	180,8	189,4	0,9322	
1000	161	329	111	279	192,9	204,6	1,0502	SCHISCHEK InMax 50.75 (75 N.m)	
1400 x	180	-	-	-	95,3	104,0	0,0931	BELIMO BEN (15 N.m)	
	200	-	-	-	97,9	106,5	0,1197		
	225	-	-	-	101,1	109,8	0,1530		
	250	-	-	-	104,2	113,0	0,1862		
	280	-	-	-	108,0	117,0	0,2261		
	300	-	-	-	110,5	119,6	0,2527		
	315	-	-	-	112,5	121,6	0,2727		
	355	-	6,5	-	-	117,4	126,8	0,3259	BELIMO BEE (25 N.m)
	400	-	29	-	-	123,2	132,7	0,3857	
	450	-	54	-	4	129,5	139,3	0,4522	
	500	-	79	-	29	135,8	145,8	0,5187	
	550	-	104	-	54	143,3	153,5	0,5852	
	560	-	109	-	59	144,6	154,9	0,5985	
	600	-	129	-	79	149,6	160,1	0,6517	
	630	-	144	-	94	153,4	164,1	0,6916	
	650	-	154	-	104	155,9	166,6	0,7182	BELIMO BE (40 N.m)
	700	11	179	-	129	162,2	173,2	0,7847	
	710	16	184	-	134	163,4	174,6	0,7980	
	750	36	204	-	154	168,5	179,7	0,8512	
	800	61	229	11	179	174,8	186,3	0,9177	
900	111	279	61	229	195,3	207,2	1,0507	SCHISCHEK InMax 50.75 (75 N.m)	
1000	161	329	111	279	207,9	220,3	1,1837		
1500 x	180	-	-	-	100,5	109,5	0,1001	BELIMO BEN (15 N.m)	
	200	-	-	-	103,2	112,2	0,1287		
	225	-	-	-	106,5	115,7	0,1645		
	250	-	-	-	109,8	119,1	0,2002		
	280	-	-	-	113,7	123,3	0,2431		
	300	-	-	-	116,4	125,9	0,2717		
	315	-	-	-	118,3	128,0	0,2932		
	355	-	6,5	-	-	123,6	133,5	0,3504	BELIMO BEE (25 N.m)
	400	-	29	-	-	129,6	139,7	0,4147	
	450	-	54	-	4	136,3	146,5	0,4862	
	500	-	79	-	29	142,8	153,4	0,5577	
550	-	104	-	54	150,7	161,5	0,6292	BELIMO BE (40 N.m)	

Sizes listed within the maximum/minimum sizes can be manufactured on request.

A x B [mm]	Damper blade overlaps without flanges		Damper blade overlaps with flanges		Weight [kg]		Effective area $S_{ef}$ [m <sup>2</sup> ]	Actuating mechanism type	
	a [mm]	c [mm]	e [mm]	f [mm]	Without flanges	With flanges			
1500 x	560	-	109	-	59	151,9	162,7	0,6435	BELIMO BE (40 N.m)
	600	-	129	-	79	157,2	168,2	0,7007	
	630	-	144	-	94	161,2	172,4	0,7436	
	650	-	154	-	104	163,9	175,1	0,7722	
	700	11	179	-	129	170,4	181,9	0,8437	
	710	16	184	-	134	171,8	183,3	0,8580	
	750	36	204	-	154	177,1	188,8	0,9152	
	800	61	229	11	179	183,7	195,6	0,9867	
	900	111	279	61	229	204,7	217,2	1,1297	
	1000	161	329	111	279	217,9	230,9	1,2727	
1600 x	180	-	-	-	-	105,7	115,1	0,1071	BELIMO BEN (15 N.m)
	200	-	-	-	-	108,4	118,0	0,1377	
	225	-	-	-	-	111,9	121,6	0,1760	
	250	-	-	-	-	115,3	125,1	0,2142	
	280	-	-	-	-	119,5	129,5	0,2601	
	300	-	-	-	-	122,2	132,4	0,2907	
	315	-	-	-	-	124,3	134,4	0,3137	
	355	-	6,5	-	-	129,8	140,2	0,3749	
	400	-	29	-	-	136,0	146,6	0,4437	
	450	-	54	-	4	142,9	153,8	0,5202	
	500	-	79	-	29	149,8	160,9	0,5967	BELIMO BEE (25 N.m)
	550	-	104	-	54	158,0	169,3	0,6732	
	560	-	109	-	59	159,4	170,7	0,6885	
	600	-	129	-	79	164,9	176,4	0,7497	
	630	-	144	-	94	169,1	180,7	0,7956	
	650	-	154	-	104	171,8	183,5	0,8262	
	700	11	179	-	129	178,7	190,7	0,9027	
	710	16	184	-	134	180,1	192,2	0,9180	
	750	36	204	-	154	185,6	197,8	0,9792	
	800	61	229	11	179	192,5	205,0	1,0557	
900	111	279	61	229	214,1	227,1	1,2087	SCHISCHEK InMax 50.75 (75 N.m)	
1000	161	329	111	279	228,0	241,4	1,3617		

Sizes listed within the maximum/minimum sizes can be manufactured on request.

## IV. INSTALLATION

### Placement and installation

- Dampers are designed to remove heat and combustion products (e.g. smoke) from fire compartments
- Dampers are suitable for installation in vertical and horizontal position passages of fire separating constructions. The damper installation procedures must be done so that all load transfer from the fire separating constructions to the damper is absolutely excluded.
- Following air-conditioning duct must be suspended or supported so that all load transfer from the following duct to the damper flange is absolutely excluded.
- The gap between the installed damper and the fire separating construction must be perfectly filled with approved material.
- After installing the damper, the damper blades must only be opened, or closed by operation of the actuator only.
- The distance between the damper and the construction (wall, ceiling) must be 75 mm at the minimum, according to BS EN 1366-2. If two or more dampers are to be installed in one fire separating construction, the distance between adjacent dampers must be 200 mm at the minimum, according to BS EN 1366-10.
- To provide the necessary space for access to the control device, it is recommended that other objects be at least 350 mm away from the control parts of the damper.

#### Minimum distance between the dampers and the construction

- minimum distance 200 mm between dampers, according to BS EN 1366-10
- minimum distance 75 mm between damper and construction (wall/ceiling), according to BS EN 1366-10

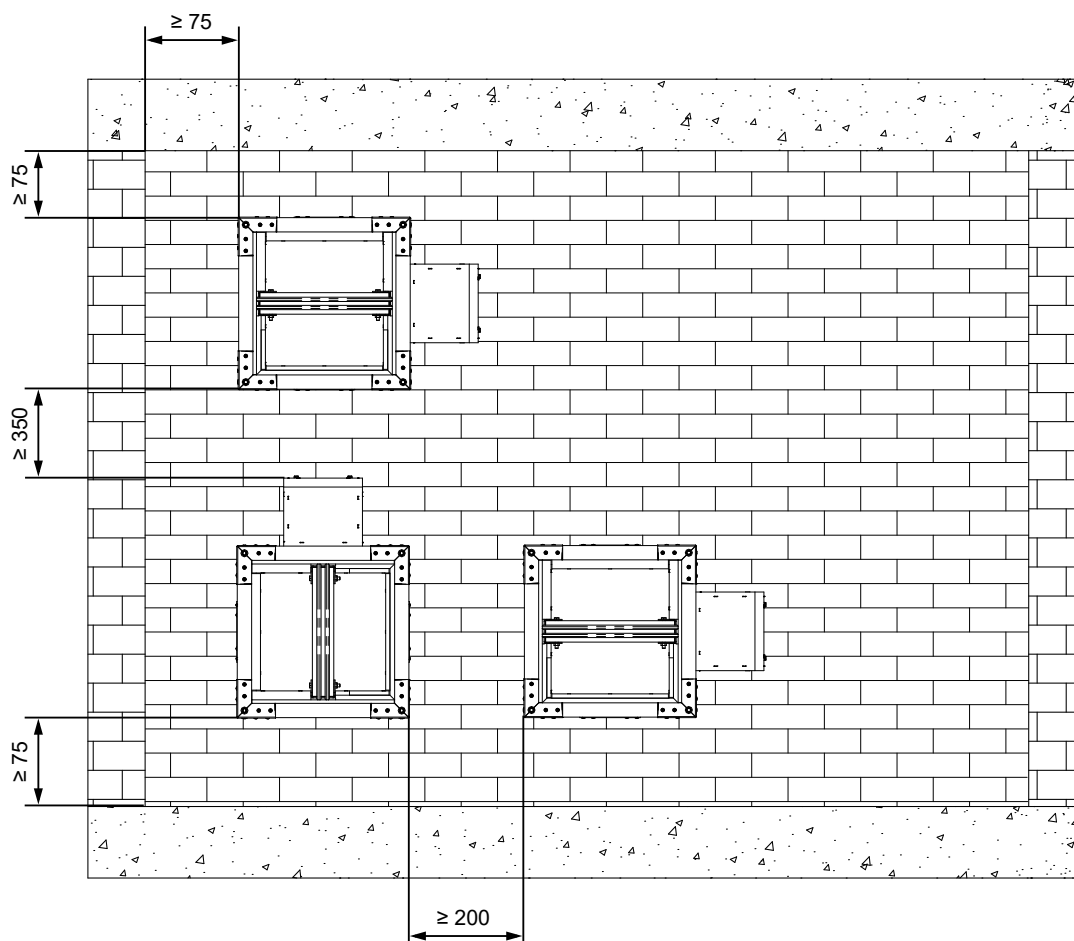

- This is the BS EN1366-2 test standard distances. They are considered as minimum. Actual location should be based on wall manufacturers requirements.
- Always consult the wall manufacturers specific guidelines for deflection heads, penetration size, location to other services, fire stopping and load bearing capacity.
- With smoke control ducting then refer to duct manufacturers tested parameters for spacing & pattern requirements.
- No other services should pass through the dampers building work opening.

**Dimensions of an installation opening  
ABLATIVE COATED BATT**

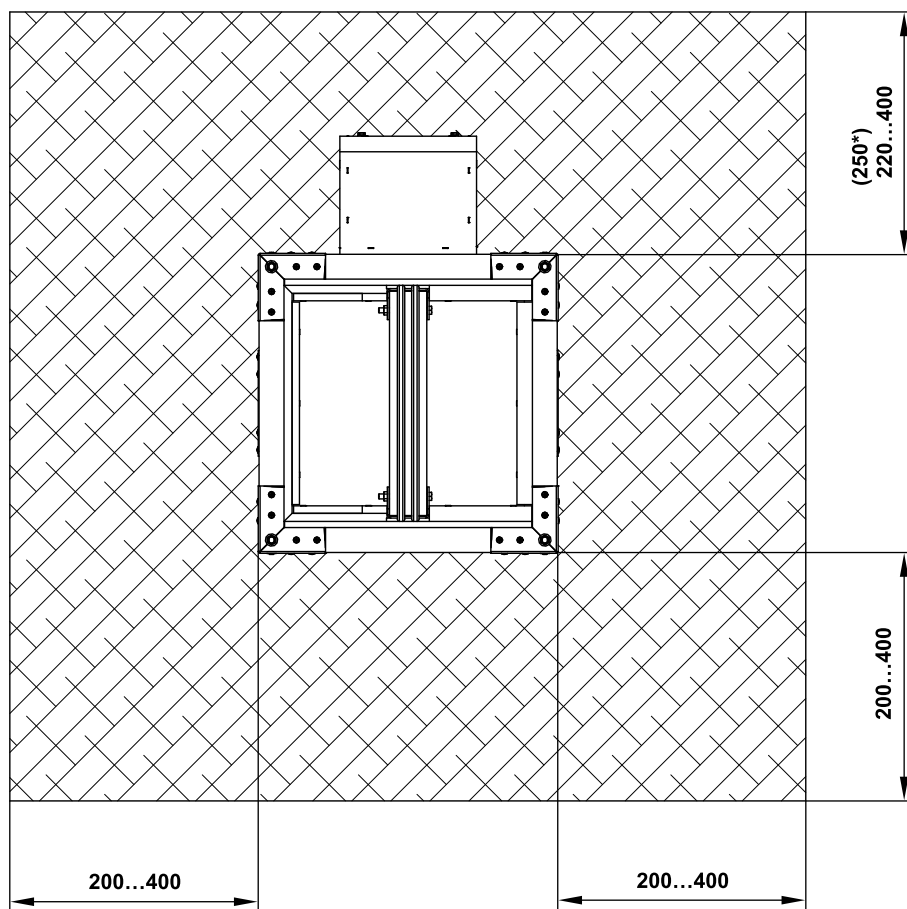

\* Dimensions with actuating mechanism InMax 50.75S.

**Statement of installations**

Type of construction	Min. thickness of construction [mm]	Penetration seal	Classification	Page
In solid wall construction	100			26
In gypsum wall construction	100		EI 120 (v <sub>ew</sub> i↔o) S1500C <sub>mod</sub> HOT 400/30MAmulti	27
In solid ceiling construction	150		EI 120 (h <sub>ow</sub> i↔o) S1500C <sub>mod</sub> HOT 400/30AAmulti	28
Battery in solid wall construction	100	Ablative Coated Batt		29
			2 dampers side by side	
Battery in gypsum wall construction	100			31
			2 dampers on top of each other	EI 120 (v <sub>ew</sub> i↔o) S1500C <sub>mod</sub> HOT 400/30MAmulti
Battery in gypsum wall construction	100			30
			2 dampers side by side	
				32
Horizontal or vertical smoke extraction ducts	Connection to single or multi compartment smoke extraction ducts tested according to BS EN 1366-8 or BS EN 1366-9		EI 120 (h <sub>od</sub> -V <sub>ed</sub> i↔o) S1000C <sub>mod</sub> HOT 400/30MAmulti	33-34

Images of plasterboard construction according to Rigips instructions (substitutes can be used such as British Gypsum, Knauf or Lafarge products that are the same overall wall thickness & EI performance on both sides).

The smoke control damper can be integrated into a gypsum wall construction with fire classification EI120 or EI 90.

## Installation in solid wall construction of fire compartment

### Solid wall - Ablative Coated Batt - vertical blade axis position

EI 120 S

- For connection following duct → see pages 42 to 44
- Examples of anchors to the fire dividing construction → see pages 39 to 41

- 1 SEDM
- 2 Solid wall construction
- 3 Profile with threaded rod → see pages 33 to 36
- 4 Actuator cover - must be removable after installation of the damper
- 5 Flange
- Ablative Coated Batt System HILTI
- 6 Mineral wool board - min. density 140 kg/m<sup>3</sup> (HILTI CFS-CT B 1S 140/50...)
- 7 Fire stop coating - th. 1 mm (HILTI CFS-CT...) - coating is overcoated on the support construction and on the damper casing/duct.
- 8 Fire-resistant mastic - (HILTI CFS-S ACR...) fill the gap from both sides of the fire separation construction and around the perimeter of penetration and damper casing.

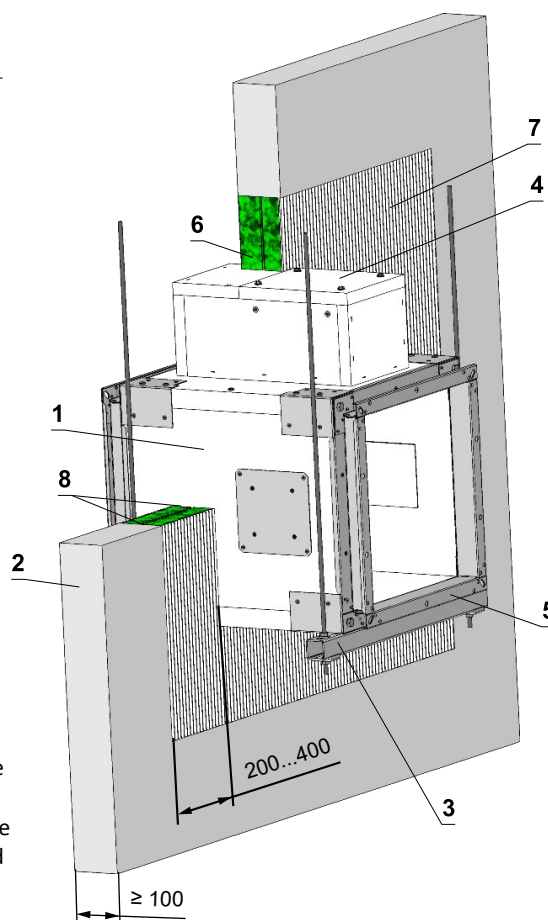

### Solid wall - Ablative Coated Batt - horizontal blade axis position

EI 120 S

- For connection following duct → see pages 42 to 44
- Examples of anchors to the fire dividing construction → see pages 39 to 41

- 1 SEDM
- 2 Solid wall construction
- 3 Profile with threaded rod → see pages 33 to 36
- 4 Actuator cover - must be removable after installation of the damper
- 5 Flange
- Ablative Coated Batt System HILTI
- 6 Mineral wool board - min. density 140 kg/m<sup>3</sup> (HILTI CFS-CT B 1S 140/50...)
- 7 Fire stop coating - th. 1 mm (HILTI CFS-CT...) - coating is overcoated on the support construction and on the damper casing/duct.
- 8 Fire-resistant mastic - (HILTI CFS-S ACR...) fill the gap from both sides of the fire separation construction and around the perimeter of penetration and damper casing.

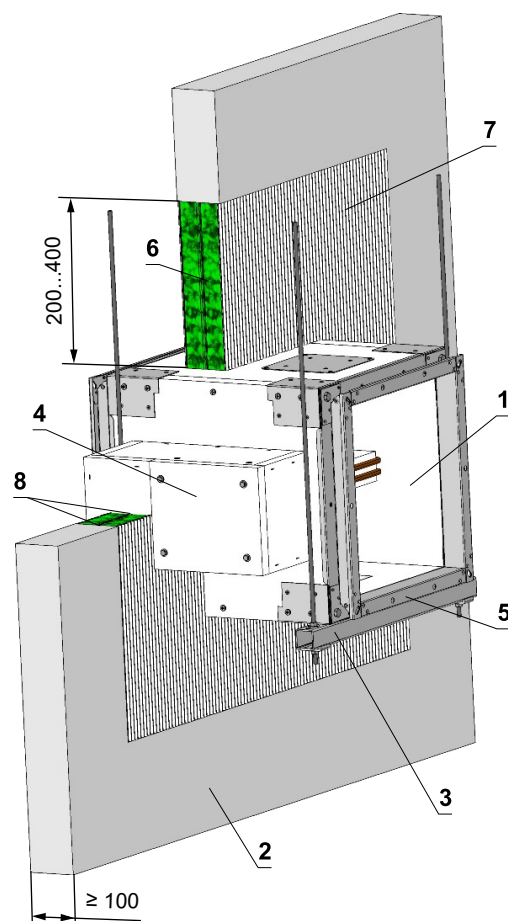

## Installation in gypsum wall construction of fire compartment

### Gypsum wall - Ablative Coated Batt - vertical blade axis position

- For connection following duct → see pages 42 to 44
- Examples of anchors to the fire dividing construction → see pages 39 to 41

- 1 SEDM
- 2 Gypsum wall construction
- 3 Profile with threaded rod → see pages 33 to 36
- 4 Actuator cover - must be removable after installation of the damper
- 5 Flange
- Ablative Coated Batt System HILTI
- 6 Mineral wool board - min. density 140 kg/m<sup>3</sup> (HILTI CFS-CT B 1S 140/50...)
- 7 Fire stop coating - th. 1 mm (HILTI CFS-CT...) - coating is overcoated on the support construction and on the damper casing/duct.
- 8 Fire-resistant mastic - (HILTI CFS-S ACR...) fill the gap from both sides of the fire separation construction and around the perimeter of penetration and damper casing.

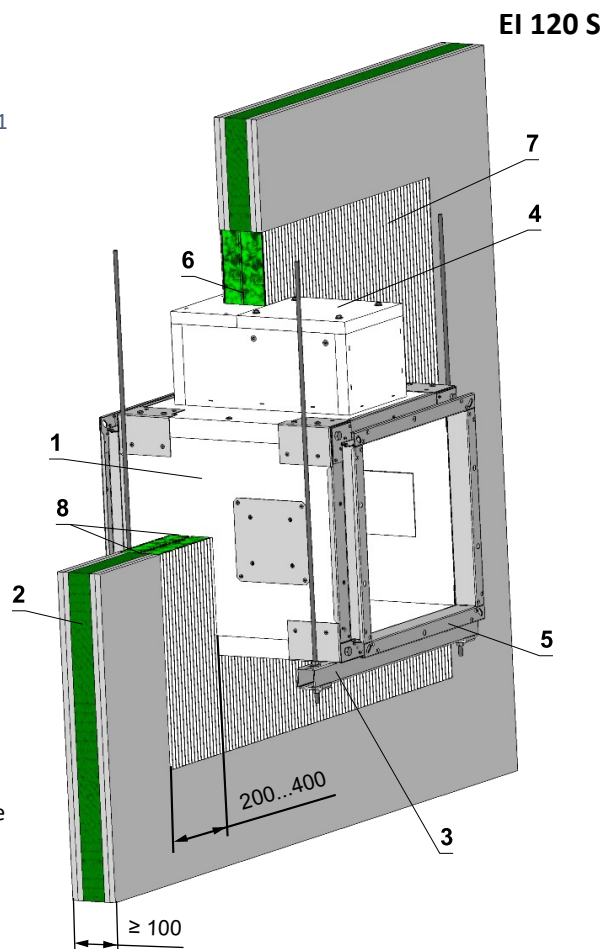

### Gypsum wall - Ablative Coated Batt - horizontal blade axis position

- For connection following duct → see pages 42 to 44
- Examples of anchors to the fire dividing construction → see pages 39 to 41

- 1 SEDM
- 2 Gypsum wall construction
- 3 Profile with threaded rod → see pages 33 to 36
- 4 Actuator cover - must be removable after installation of the damper
- 5 Flange
- Ablative Coated Batt System HILTI
- 6 Mineral wool board - min. density 140 kg/m<sup>3</sup> (HILTI CFS-CT B 1S 140/50...)
- 7 Fire stop coating - th. 1 mm (HILTI CFS-CT...) - coating is overcoated on the support construction and on the damper casing/duct.
- 8 Fire-resistant mastic - (HILTI CFS-S ACR...) fill the gap from both sides of the fire separation construction and around the perimeter of penetration and damper casing.

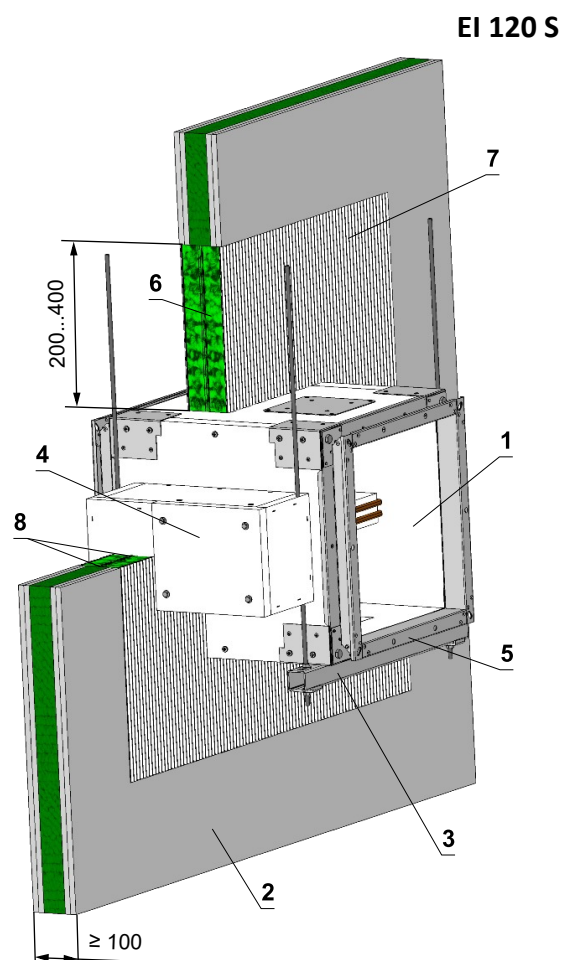

## Installation in solid ceiling construction of fire compartment

### In solid ceiling construction - Ablative Coated Batt - actuator under ceiling

EI 120 S

- For connection of following duct → see pages 42 to 44
- Examples of anchors to the fire dividing construction → see pages 39 to 41
- Number of L-holders and their placement, acc. to AxB dimension → see page 37

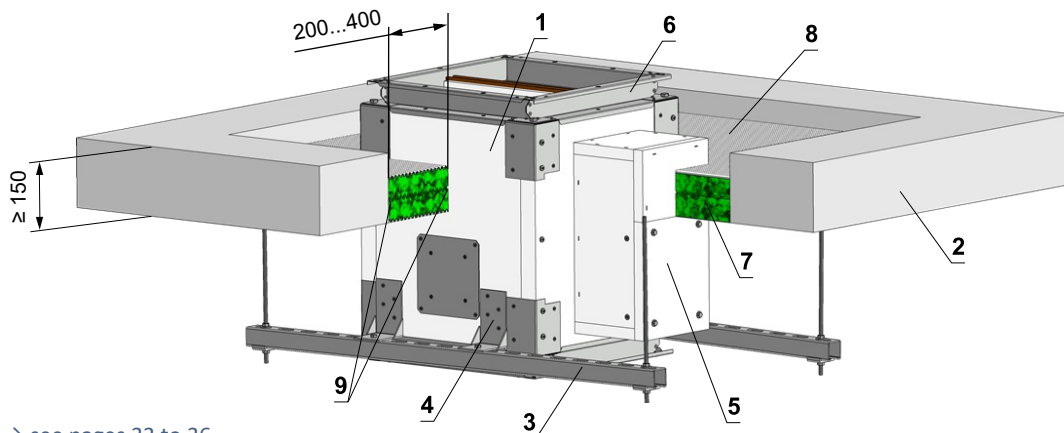

- 1 SEDM
- 2 Solid ceiling construction
- 3 Profile with threaded rod → see pages 33 to 36
- 4 L-holder → see page 37
- 5 Actuator cover - must be removable after installation of the damper
- 6 Flange  
Ablative Coated Batt System HILTI
- 7 Mineral wool board - min. density 140 kg/m<sup>3</sup> (HILTI CFS-CT B 1S 140/50...)
- 8 Fire stop coating - th. 1 mm (HILTI CFS-CT...) - coating is overcoated on the support construction and on the damper casing/duct.
- 9 Fire-resistant mastic - (HILTI CFS-S ACR...) fill the gap from both sides of the fire separation construction and around the perimeter of penetration and damper casing.

### In solid ceiling construction - Ablative Coated Batt - actuator above ceiling

EI 120 S

- For connection of following duct → see pages 42 to 44
- Examples of anchors to the fire dividing construction → see pages 39 to 41
- Number of L-holders and their placement, acc. to AxB dimension → see page 37

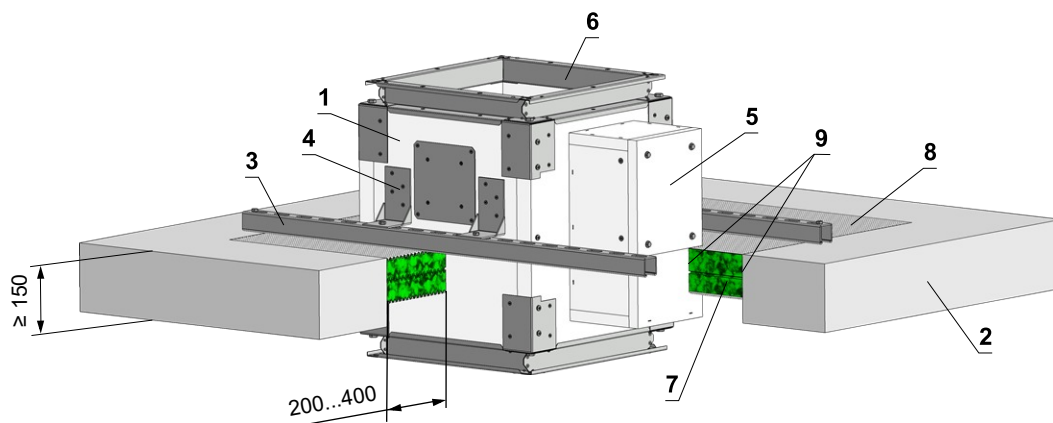

- 1 SEDM
- 2 Solid ceiling construction
- 3 Fixing profile HILTI MQ-41 (or MQ-41/3 or equivalent) → see page 36
- 4 L-holder → see page 37
- 5 Actuator cover - must be removable after installation of the damper
- 6 Flange  
Ablative Coated Batt System HILTI
- 7 Mineral wool board - min. density 140 kg/m<sup>3</sup> (HILTI CFS-CT B 1S 140/50...)
- 8 Fire stop coating - th. 1 mm (HILTI CFS-CT...) - coating is overcoated on the support construction and on the damper casing/duct.
- 9 Fire-resistant mastic - (HILTI CFS-S ACR...) fill the gap from both sides of the fire separation construction and around the perimeter of penetration and damper casing.

Installation in battery

2 dampers side by side - solid wall - Ablative Coated Batt

EI 120 S

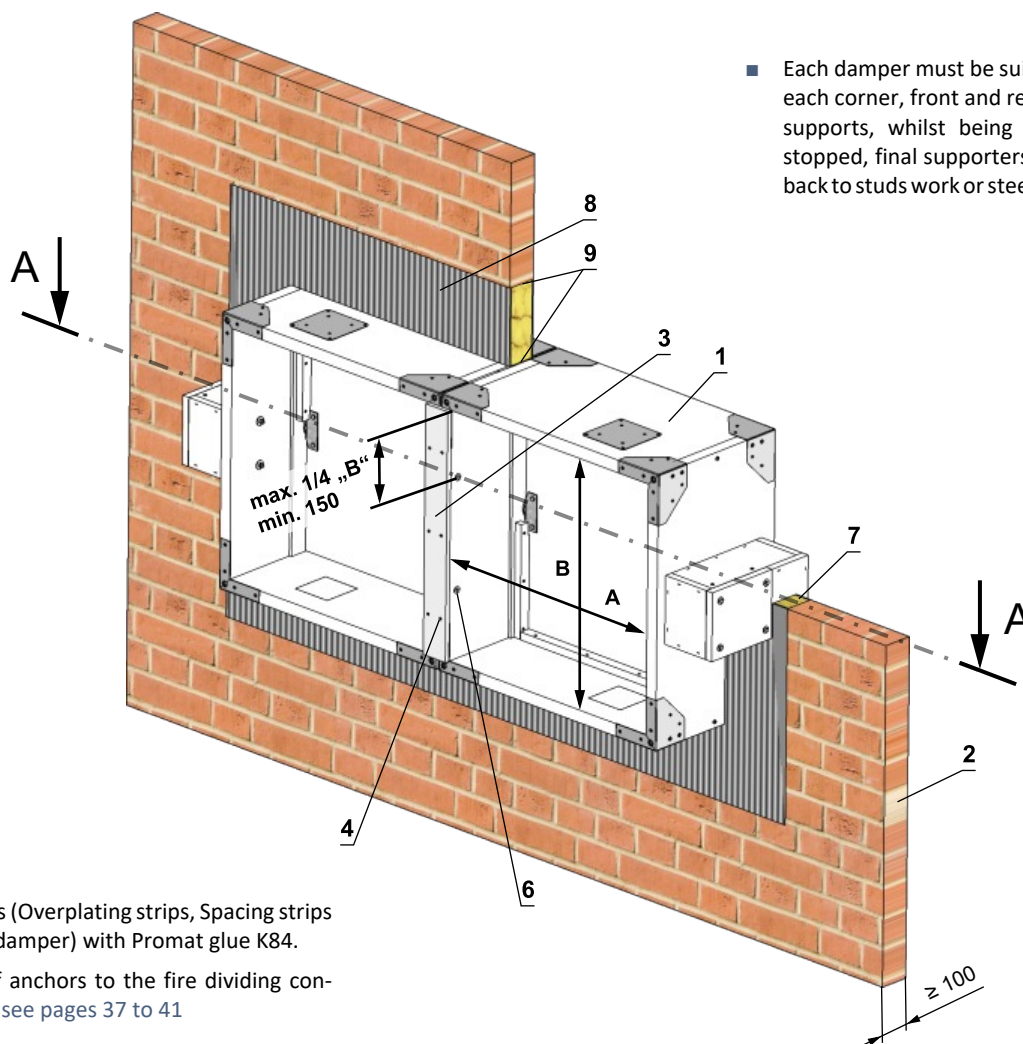

■ Each damper must be suitably supported in each corner, front and rear with temporary supports, whilst being installed and fire stopped, final supporters must be installed back to studs work or steel work as required.

- Seal all joints (Overplating strips, Spacing strips with SEDM damper) with Promat glue K84.
- Examples of anchors to the fire dividing construction → see pages 37 to 41

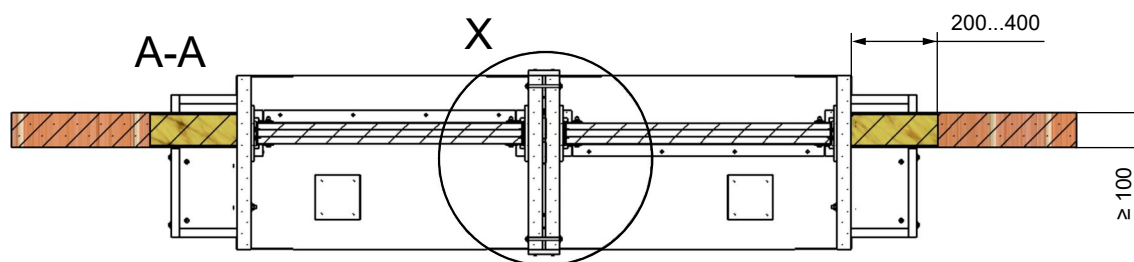

\* RESPECT JOINT POSITION !

Bolts and nuts shall not prevent free rotation on the blades.

\*\* When installing a flange, overplating strip is not installed.

- 1 SEDM
  - 2 Solid wall construction
  - 3 Overplating strip (e.g. Supalux-S, th. 15 mm)\*\*
  - 4 Screw UNI 4x40 mm (span 200-250 mm)
  - 5 Spacing strip (e.g. Supalux-S, th. 12 mm, width 40-50 mm)
  - 6 M8 bolt assembly on damper side „B“ (bolt M8x105 mm, 2x large washer M8, nut M8), distance from edge see fig. \*
- Ablative Coated Batt System HILTI
- 7 Mineral wool board - min. density 140 kg/m<sup>3</sup> (HILTI CFS-CT B 1S 140/50...)
  - 8 Fire stop coating - th. 1 mm (HILTI CFS-CT...) - coating is overcoated on the support construction and on the damper casing/duct.
  - 9 Fire-resistant mastic - (HILTI CFS-S ACR...) fill the gap from both sides of the fire separation construction and around the perimeter of penetration and damper casing.

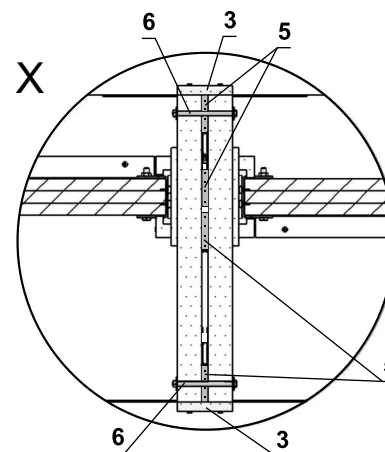

Connecting straps, spacer straps, screws, screw connections and Promat glue K84 are not included in the delivery !

2 dampers side by side - gypsum wall - Ablative Coated Batt

EI 120 S

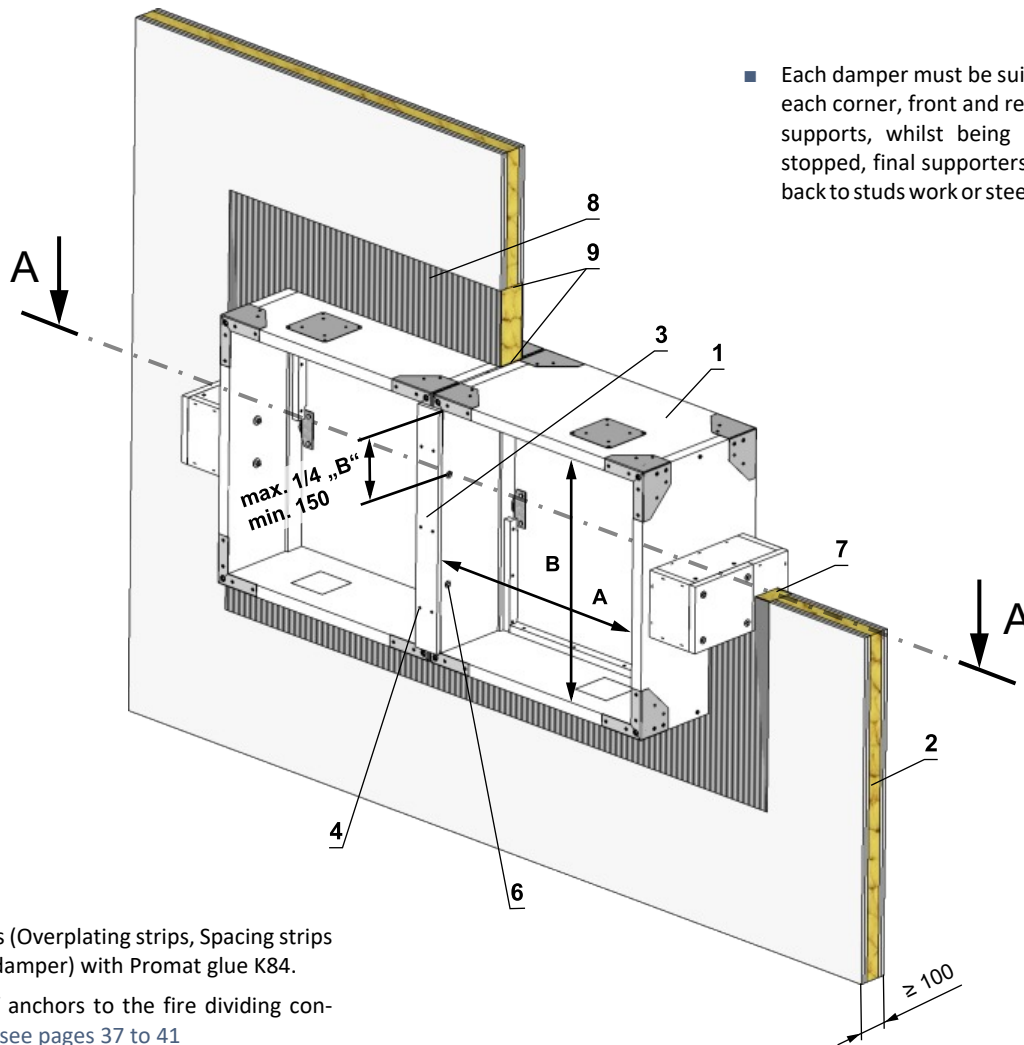

- Seal all joints (Overplating strips, Spacing strips with SEDM damper) with Promat glue K84.
- Examples of anchors to the fire dividing construction → see pages 37 to 41

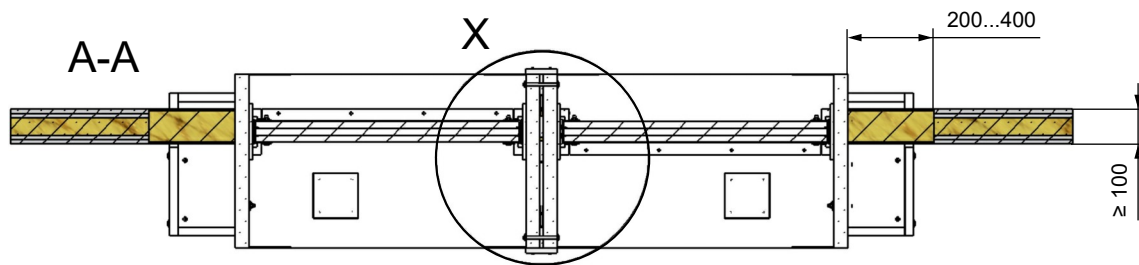

- \* **RESPECT JOINT POSITION !**  
Bolts and nuts shall not prevent free rotation on the blades.
- \*\* When installing a flange, overplating strip is not installed.

- 1 SEDM
- 2 Gypsum wall construction
- 3 Overplating strip (e.g. Supalux-S, th. 15 mm)\*\*
- 4 Screw UNI 4x40 mm (span 200-250 mm)
- 5 Spacing strip (e.g. Supalux-S, th. 12 mm, width 40-50 mm)
- 6 M8 bolt assembly on damper side „B“ (bolt M8x105 mm, 2x large washer M8, nut M8), distance from edge see fig. \*
- Ablative Coated Batt System HILTI
- 7 Mineral wool board - min. density 140 kg/m<sup>3</sup> (HILTI CFS-CT B 1S 140/50...)
- 8 Fire stop coating - th. 1 mm (HILTI CFS-CT...) - coating is overcoated on the support construction and on the damper casing/duct.
- 9 Fire-resistant mastic - (HILTI CFS-S ACR...) fill the gap from both sides of the fire separation construction and around the perimeter of penetration and damper casing.

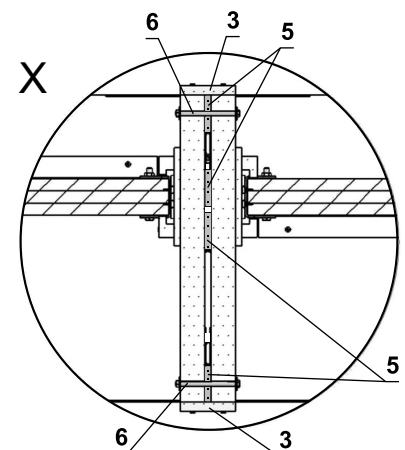

**Connecting straps, spacer straps, screws, screw connections and Promat glue K84 are not included in the delivery !**

2 dampers on top of each other - solid wall - Ablative Coated Batt

EI 120 S

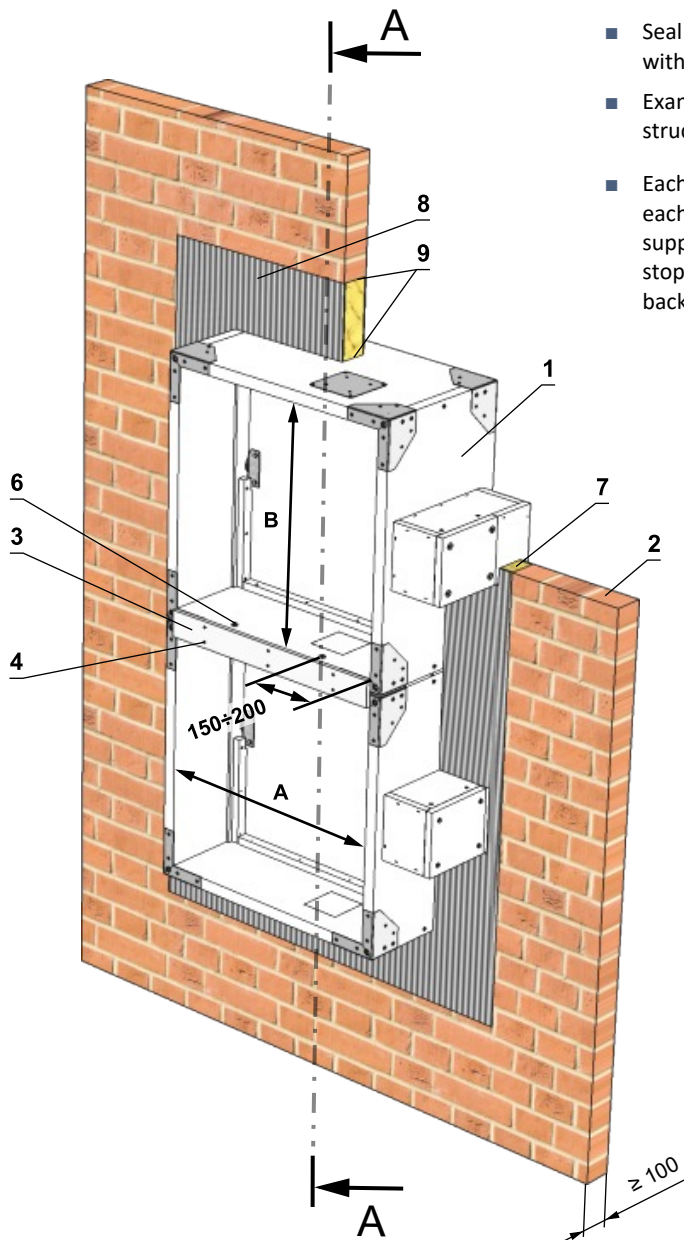

- Seal all joints (Overplating strips, Spacing strips with SEDM damper) with Promat glue K84.
- Examples of anchors to the fire dividing construction → see pages 37 to 41
- Each damper must be suitably supported in each corner, front and rear with temporary supports, whilst being installed and fire stopped, final supportors must be installed back to studs work or steel work as required.

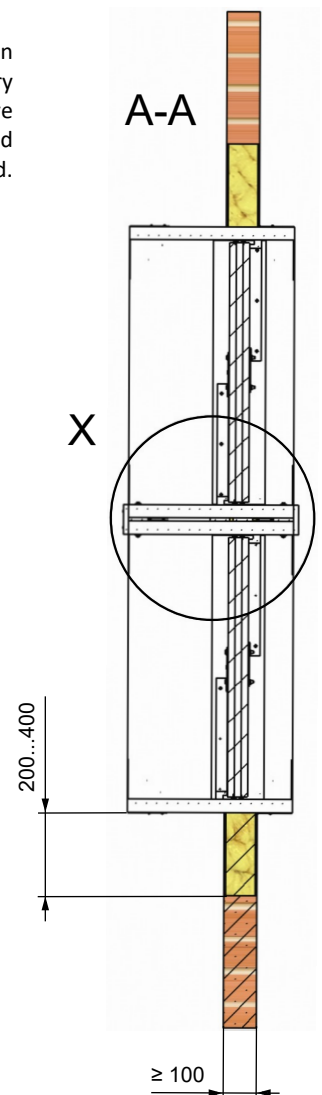

\* When installing a flange, overplating strip is not installed.

- 1 SEDM
- 2 Solid wall construction
- 3 Overplating strip (e.g. Supalux-S, th. 15 mm)\*
- 4 Screw UNI 4x40 mm (span 200-250 mm)
- 5 Spacing strip (e.g. Supalux-S, th. 12 mm, width 40-50 mm)
- 6 M8 bolt assembly on damper side „A“ (bolt M8x105 mm, 2x large washer M8, nut M8), distance from edge see fig., span max. 400 mm  
Ablative Coated Batt System HILTI
- 7 Mineral wool board - min. density 140 kg/m<sup>3</sup> (HILTI CFS-CT B 1S 140/50...)
- 8 Fire stop coating - th. 1 mm (HILTI CFS-CT...) - coating is overcoated on the support construction and on the damper casing/duct.
- 9 Fire-resistant mastic - (HILTI CFS-S ACR...) fill the gap from both sides of the fire separation construction and around the perimeter of penetration and damper casing.

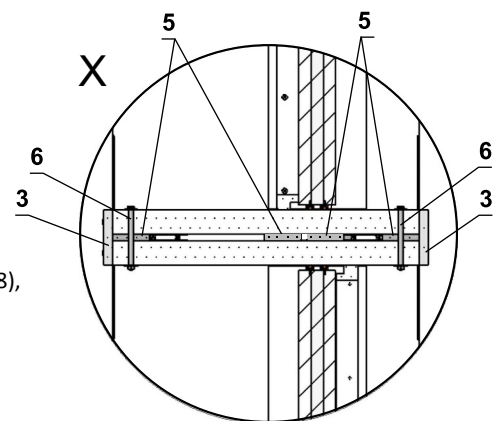

**Connecting straps, spacer straps, screws, screw connections and Promat glue K84 are not included in the delivery !**

4 dampers - gypsum wall - Ablative Coated Batt

EI 120 S

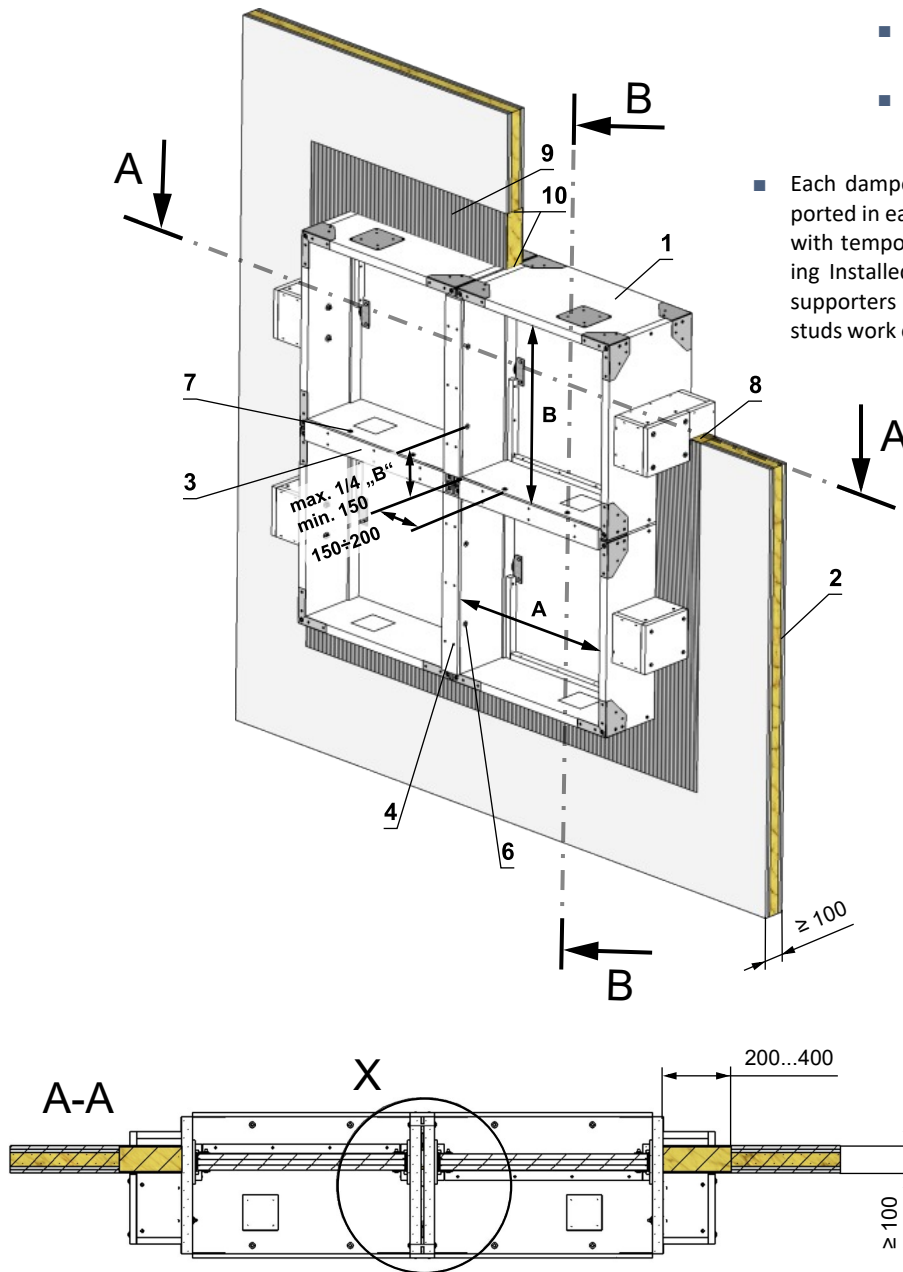

- Seal all joints (Overplating strips, Spacing strips with SEDM damper) with Promat glue K84.
- Examples of anchors to the fire dividing construction → see pages 37 to 41

- Each damper must be suitably supported in each corner, front and rear with temporary supports, whilst being installed and fire stopped, final supporters must be installed back to studs work or steel work as required.

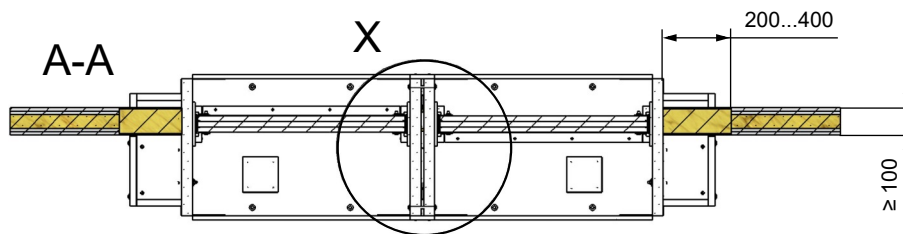
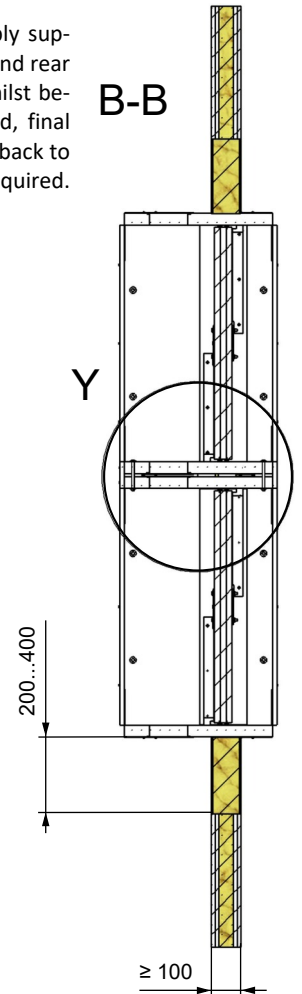

\* RESPECT JOINT POSITION !

Bolts and nuts shall not prevent free rotation on the blades.

\*\* When installing a flange, overplating strip is not installed.

- 1 SEDM
- 2 Gypsum wall construction
- 3 Overplating strip (e.g. Supalux-S, th. 15 mm)\*\*
- 4 Screw UNI 4x40 mm (span 200-250 mm)
- 5 Spacing strip (e.g. Supalux-S, th. 12 mm, width 40-50 mm)
- 6 M8 bolt assembly on damper side „B“ (bolt M8x105 mm, 2x large washer M8, nut M8), distance from edge see fig. \*
- 7 M8 bolt assembly on damper side „A“ (bolt M8x105 mm, 2x large washer M8, nut M8), distance from edge see fig., span max. 400 mm  
Ablative Coated Batt System HILTI
- 8 Mineral wool board - min. density 140 kg/m<sup>3</sup> (HILTI CFS-CT B 1S 140/50...)
- 9 Fire stop coating - th. 1 mm (HILTI CFS-CT...) - coating is overcoated on the support construction and on the damper casing/duct.
- 10 Fire-resistant mastic - (HILTI CFS-S ACR...) fill the gap from both sides of the fire separation construction and around the perimeter of penetration and damper casing.

Connecting straps, spacer straps, screws, screw connections and Promat glue K84 are not included in the delivery !

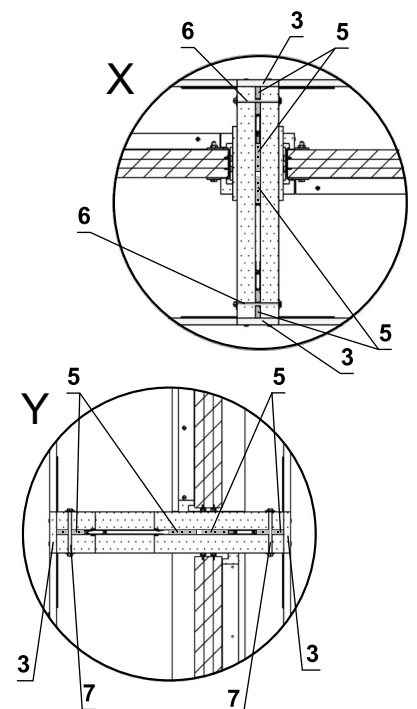

## Installation into/onto vertical or horizontal smoke extraction duct

### Installation of the damper into/onto vertical steel smoke extraction duct

EI 120 S

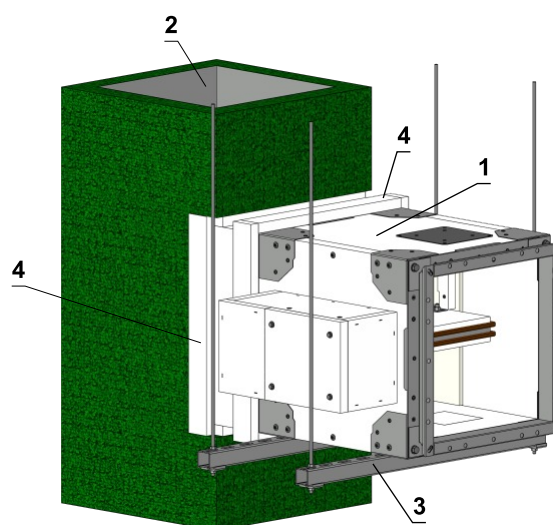
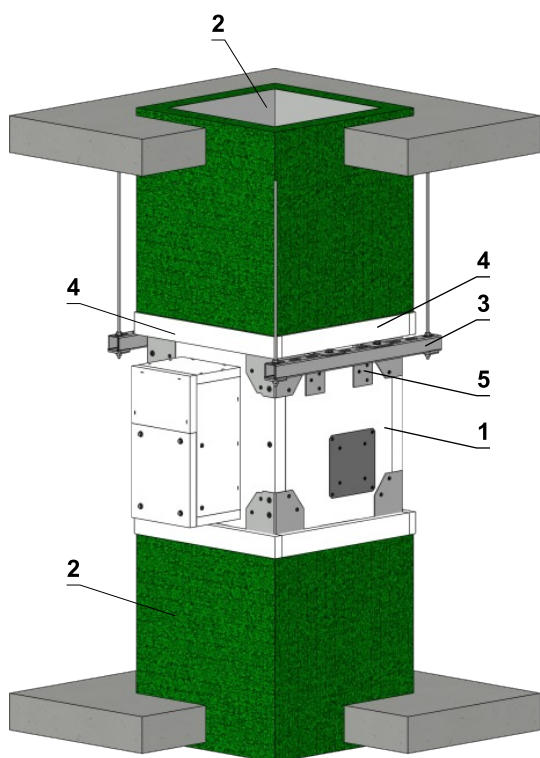

- Brackets must be mounted on sides, location and symmetry is not a specific requirement but is preferential.
- The dampers and duct must be suspended separately.
- Duct from BS EN 12101-7 in Steel (insulated or spray coated)
- Number of L-holders and their placement, acc. to AxB dimension, → see page 37
- Examples of anchors to the fire dividing construction → see pages 39 to 41
- Example of connection to duct → see pages 43 to 44

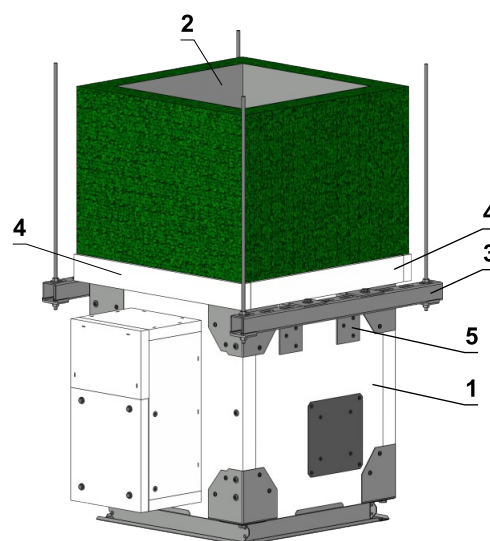
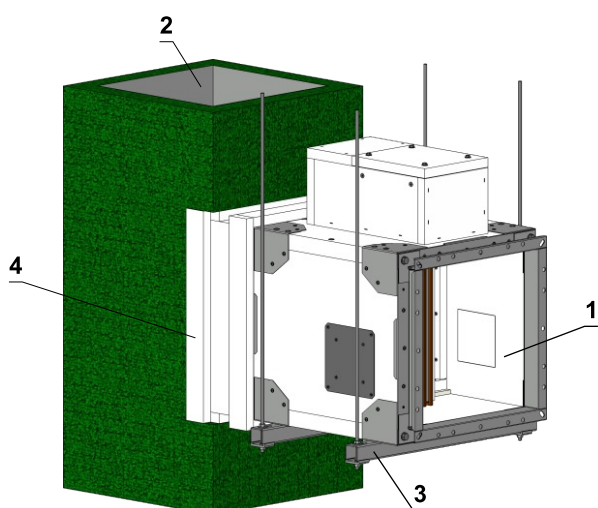

- 1 SEDM
- 2 Smoke extraction duct
- 3 Fixing profile with threaded rod → see page 36
- 4 Connection's insulation
- 5 L-holder → see pages 37 to 41

Installation of the damper into/onto horizontal steel smoke extraction duct

EI 120 S

- Brackets must be mounted on sides, location and symmetry is not a specific requirement but is preferential.
- The dampers and duct must be suspended separately.
- Duct from BS EN 12101-7 in Steel (insulated or spray coated)
- Number of L-holders and their placement, acc. to AxB dimension, → see page 37
- Examples of anchors to the fire dividing construction → see pages 39 to 41
- Example of connection to duct → see pages 43 to 44

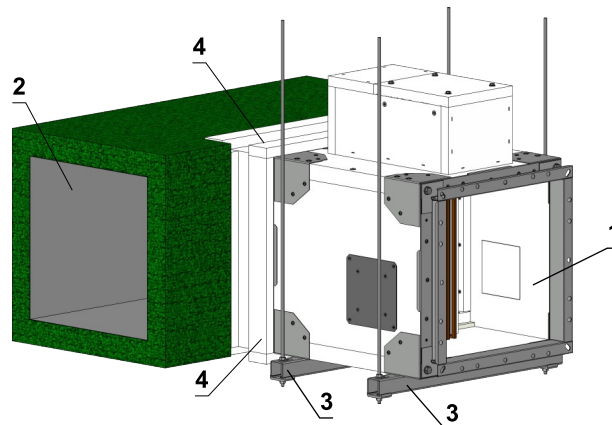
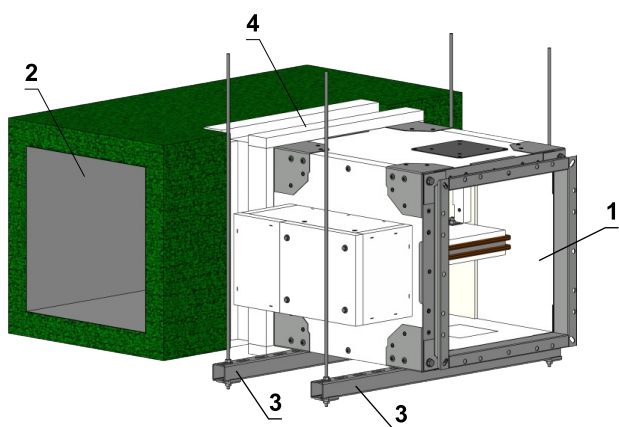
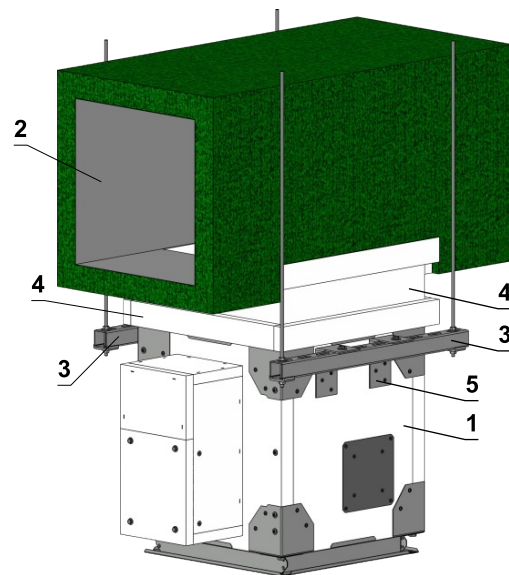
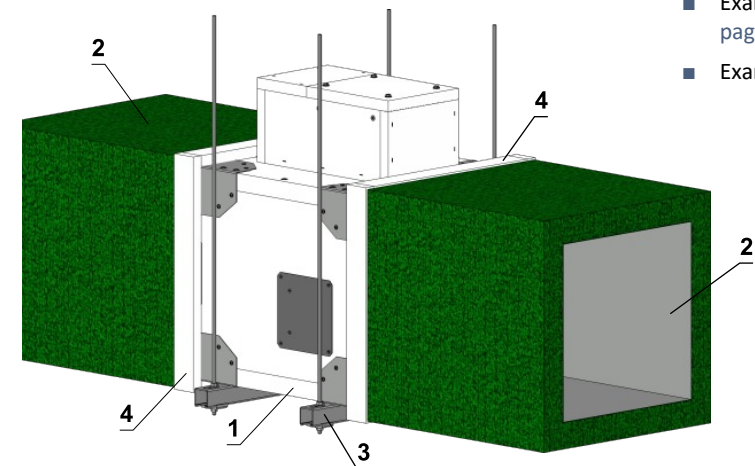

- 1 SEDM
- 2 Smoke extraction duct
- 3 Fixing profile with threaded rod → see page 36
- 4 Connection's insulation
- 5 L-holder → see pages 37 to 41

# V. SUSPENSION SYSTEMS

## Mounting to the ceiling wall

- The dampers must be suspended using threaded rods and mounting profiles. Their dimensioning depend on the weight of the damper.
- The dampers and the duct must be suspended separately.
- Following air-conditioning duct must be suspended or supported so that all load transfer from the following duct to the damper flanges is absolutely excluded. Adjacent duct must be suspended or supported, as required by the duct suppliers.
- Threaded rods longer than 1,5 m must be protected by fire insulation.

### Examples of anchoring to the ceiling construction Follow the instructions of fixing specialist or installation company

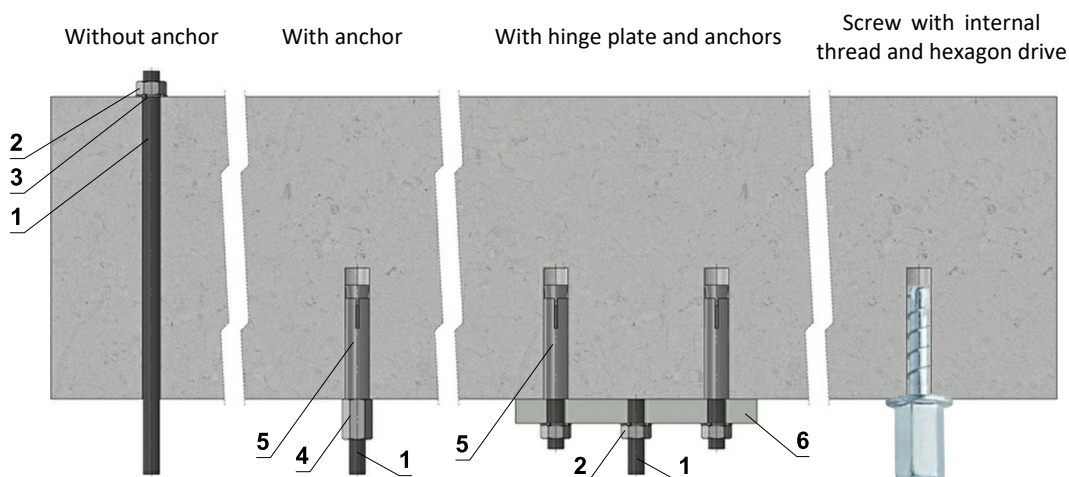

Hinge plates

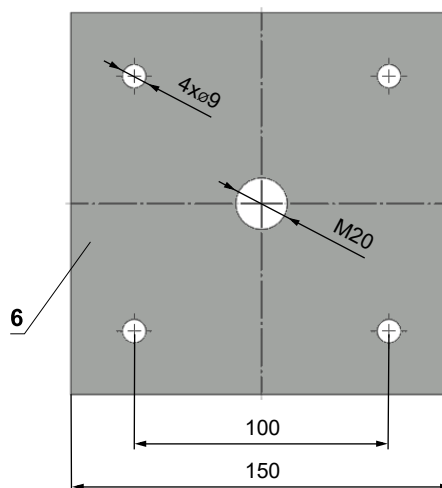
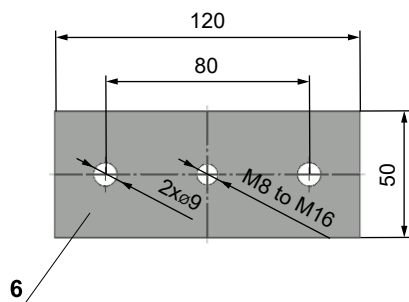

- If in doubt, always consult an anchor specialist engineer such as Halfen or Hilti.

#### Load capacities of threaded rods at the required fire resistance 60 min. <math>t \le 120 \text{ min.}</math>

Size	As [mm <sup>2</sup> ]	Weight [kg]	
		for 1 rod	for 2 rods
M8	36,6	22	44
M10	58	35	70
M12	84,3	52	104
M16	157	96	192
M18	192	117	234
M20	245	150	300

- 1 Threaded rod M8 - M20
- 2 Nut M8 - M20
- 3 Washer for M8 - M20
- 4 Coupling Nut M8 - M20
- 5 Anchor
- 6 Hinge plate - min. thickness 10 mm
- 7 Concrete screw tested for fire resistance R30-R90, max. Tension up to 0.75 KN (length 35 mm)

Example of placing of mounting profiles HILTI

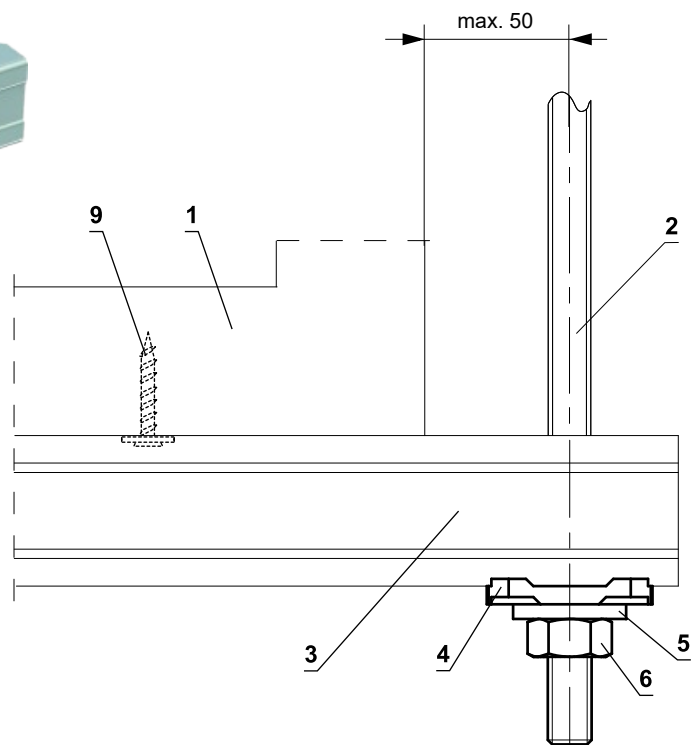
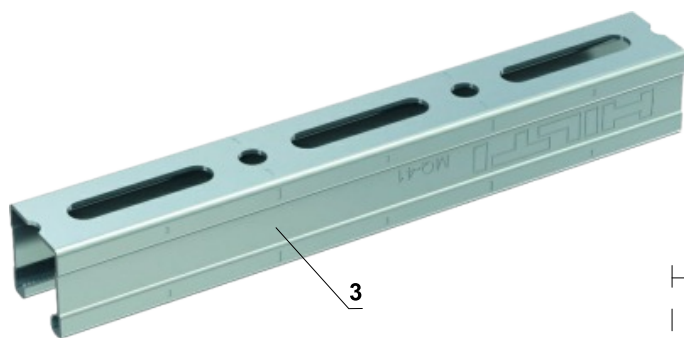
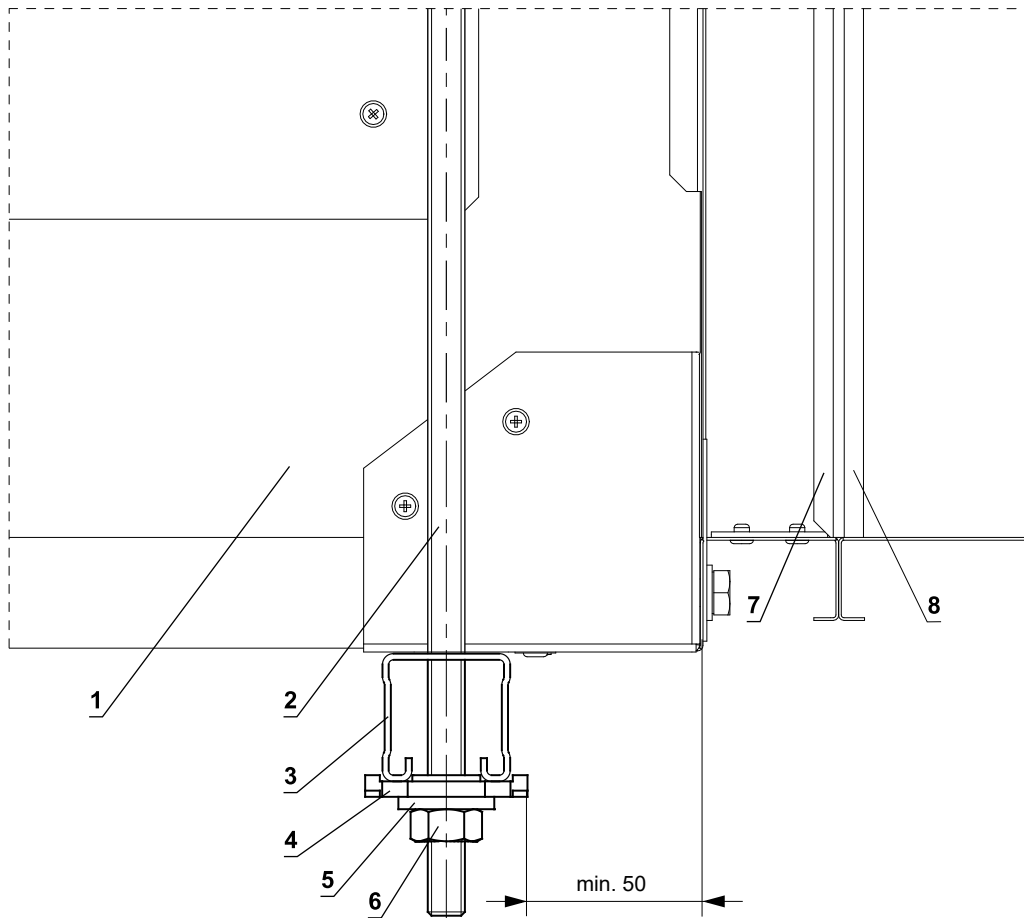

- 1 SEDM
- 2 Threaded rod M8 - M12
- 3 Support HILTI MQ-41 or MQ-41/3
- 4 Bored plate HILTI MQZ-L
- 5 Washer for M8 - M12
- 6 Nut M8 - M12
- 7 Flange of SEDM
- 8 Flange of duct
- 9 Self-tapping screw 5x30 mm and 1 pcs large washer M5 (for additional fixing, prevents the damper from sliding off the support - not necessary use)

Fixing SEDM according to size, with L-holder - tested fixing on wall / ceiling

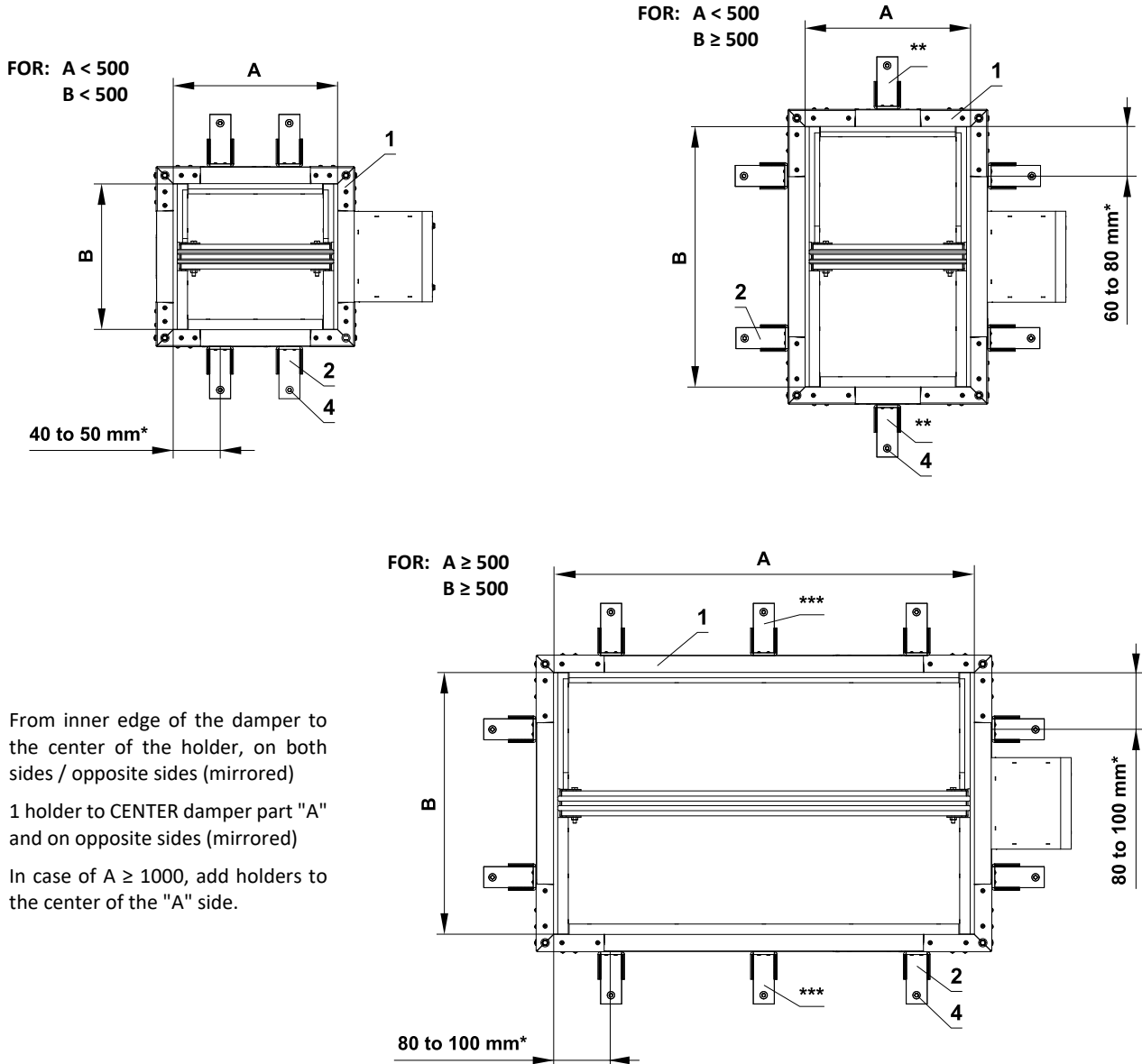

- \* From inner edge of the damper to the center of the holder, on both sides / opposite sides (mirrored)
- \*\* 1 holder to CENTER damper part "A" and on opposite sides (mirrored)
- \*\*\* In case of A ≥ 1000, add holders to the center of the "A" side.

L-holder for connecting damper on the wall / ceiling (optional accessories MANDIK, a.s.)

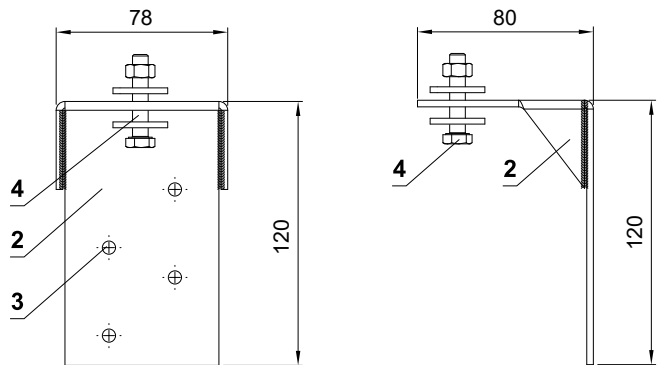

- 1 SEDM
- 2 L-holder - optional accessories from MANDIK, a.s.
- 3 Holes for screw UNI min. 5x30 mm for fastening L-holder to damper body
- 4 M8 bolt assembly (bolt min. M8x60 mm, 2 pcs large washer M8, nut M8) or Anchor to concrete, → see page 35

■ Details and examples placing of L-holder → see pages 33 to 34 and 38

**Examples placing of L-holder and Cantilever arm**

**Indicative only -final design is the responsibility of the specialist installation contractor.**

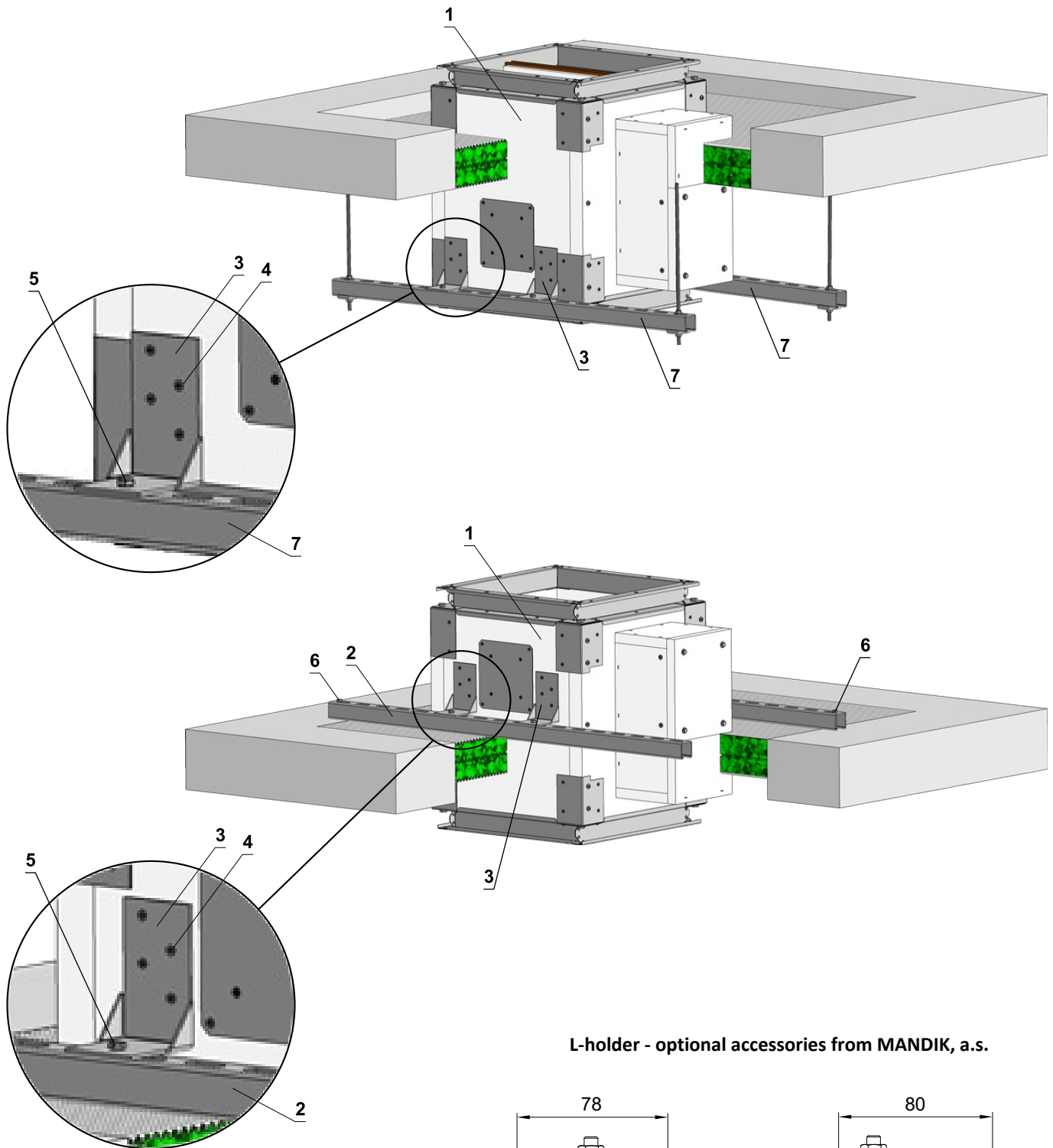

**L-holder - optional accessories from MANDIK, a.s.**

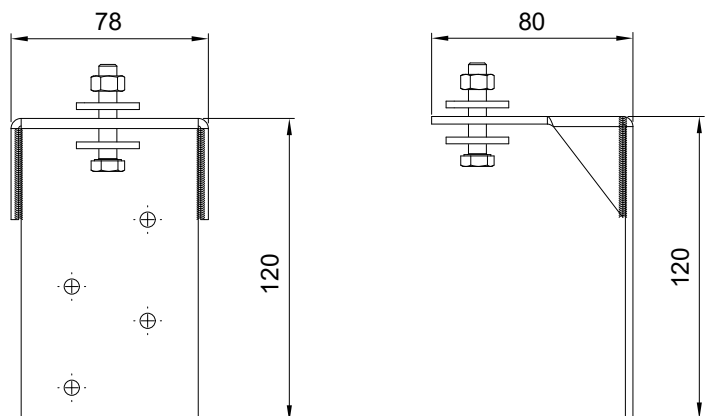

- 1 SEDM
- 2 Support HILTI MQ-41 (or MQ-41/3 or equivalent)
- 3 L-holder - optional accessories from MANDIK, a.s.
- 4 Screw UNI 5x40 mm
- 5 M8 bolt assembly (bolt min. M8x60 mm, 2 pcs large washer M8, nut M8) or equivalent
- 6 Anchor → see page 35
- 7 Fixing profile with threaded rod → see page 36

Fixing SEDM according to size - tested fixing to solid / gypsum or ceiling wall

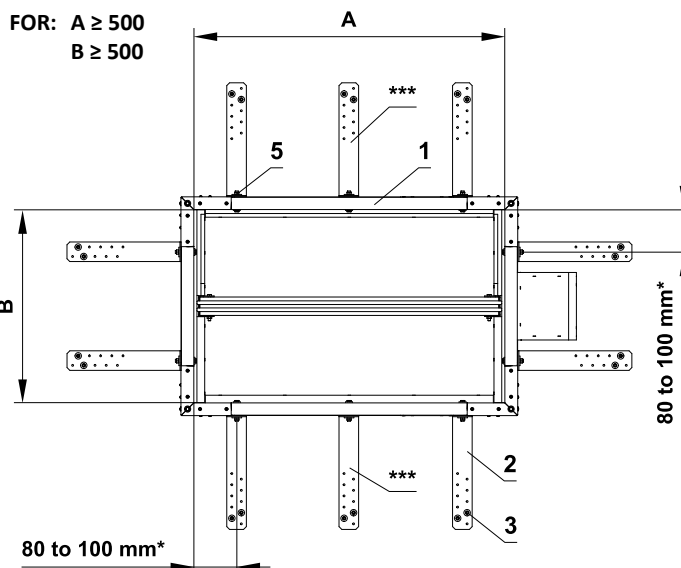
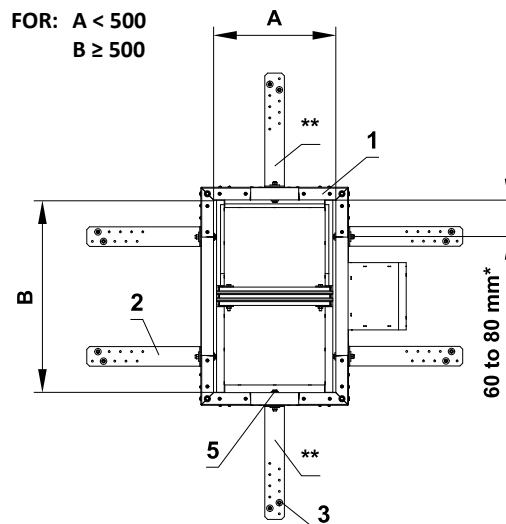
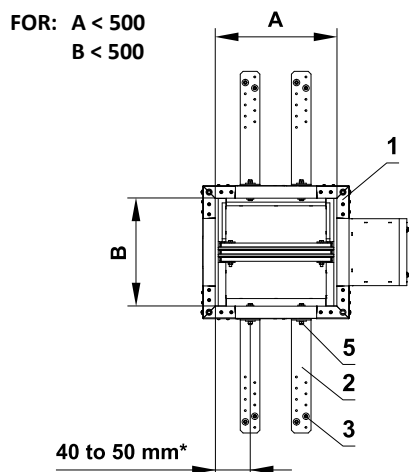

- \* From inner edge of the damper to the center of the holder, on both sides / opposite sides (mirrored)
- \*\* 1 holder to CENTER damper part "A" and on opposite sides (mirrored)
- \*\*\* In case of  $A \geq 1000$ , add holders to the center of the "A" side.

Fixing element/steel holder for connecting damper to the wall (optional accessories MANDIK, a.s.)

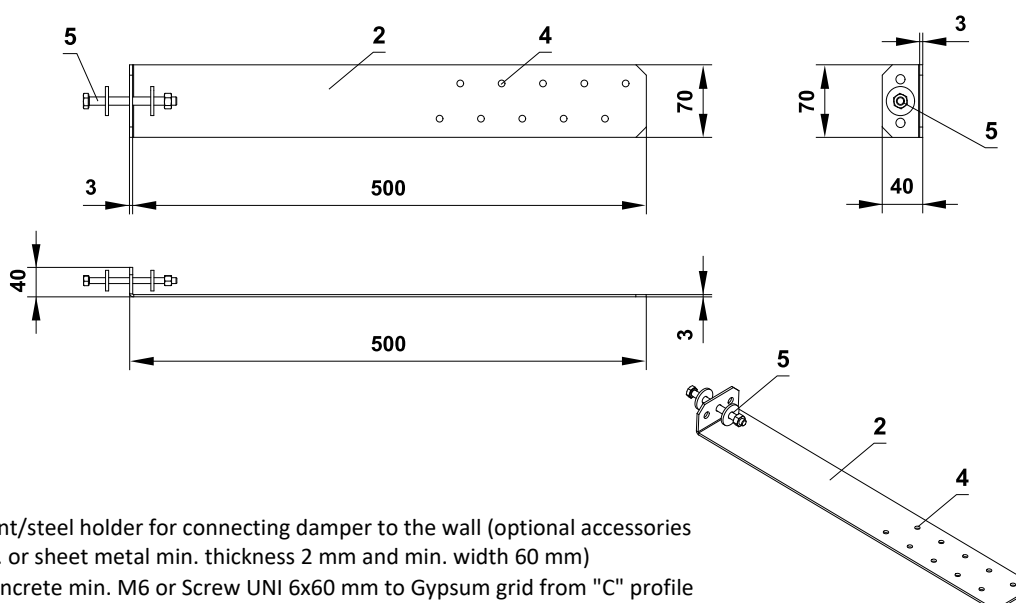

- 1 SEDM
- 2 Fixing element/steel holder for connecting damper to the wall (optional accessories MANDIK, a.s. or sheet metal min. thickness 2 mm and min. width 60 mm)
- 3 Anchor to concrete min. M6 or Screw UNI 6x60 mm to Gypsum grid from "C" profile
- 4 Installation holes
- 5 M8 bolt assembly (bolt M8x55 mm, 2 pcs large washer M8, nut M8)

■ Details → see pages 40 to 41

Fixing SEDM to the solid (ceiling) wall construction with Ablative Coated Batt system

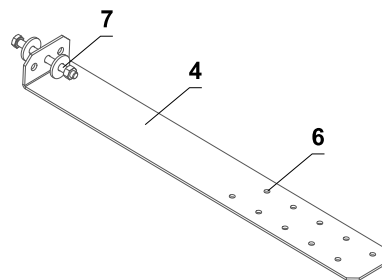
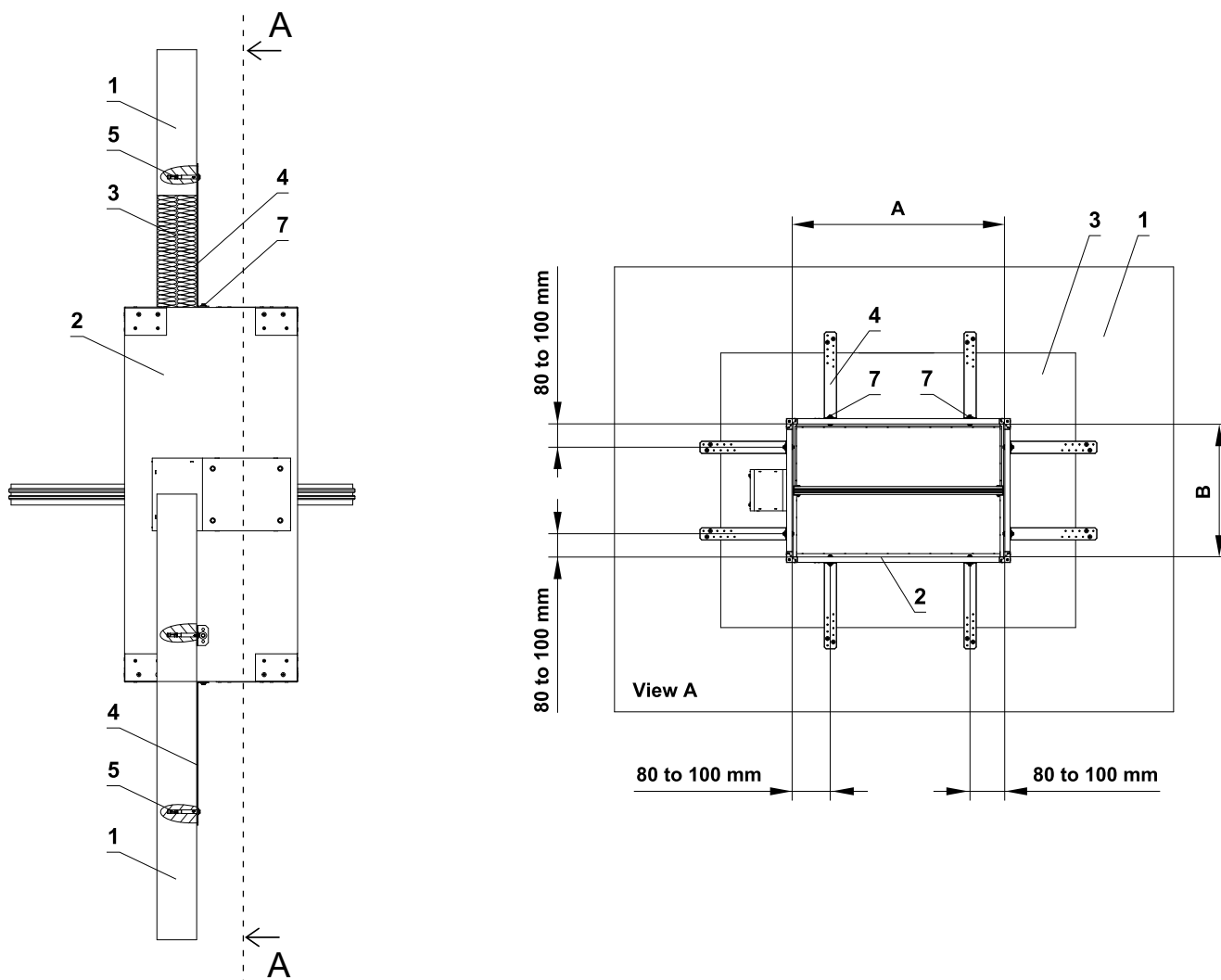

\* **ATTENTION TO THE LOCATION OF THE JOINT !**  
Screws and nuts must not impede the free rotation of Blades.

- 1 Solid wall construction
- 2 SEDM
- 3 Ablative Coated Batt
- 4 Fixing element/steel holder for connecting damper to the wall (optional accessories MANDIK, a.s. or sheet metal min. thickness 2 mm and min. width 60 mm)
- 5 Anchor to concrete min. M6
- 6 Installation holes
- 7 M8 bolt assembly (bolt M8x55 mm, 2 pcs large washer M8, nut M8) \*

■ The method of mounting must meet the minimum requirements for attachment in accordance with national regulations.

Fixing SEDM to the gypsum wall construction with Ablative Coated Batt system

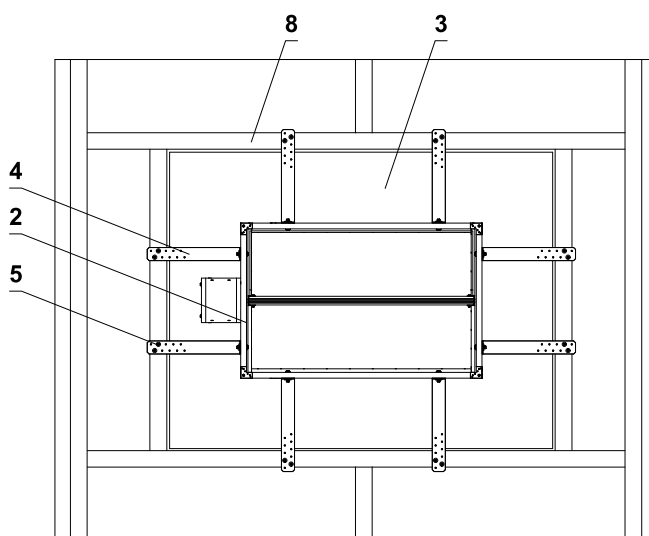
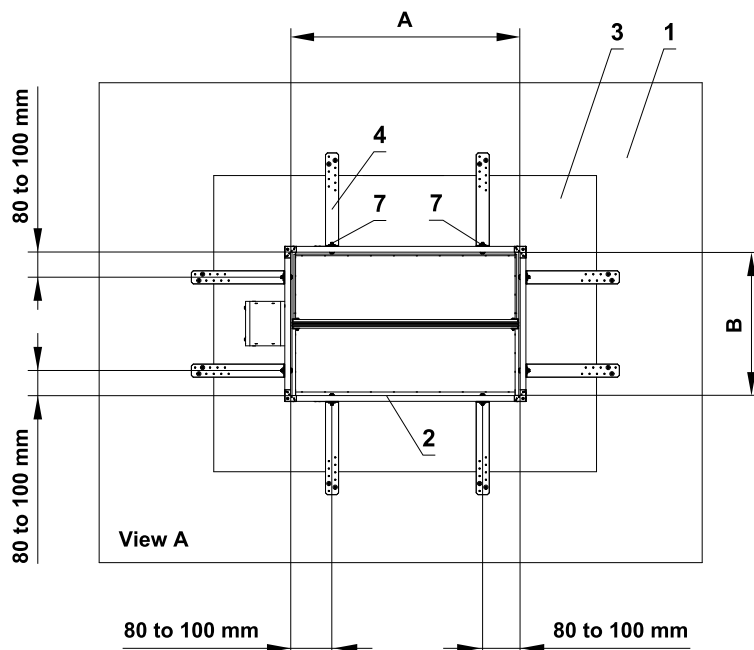
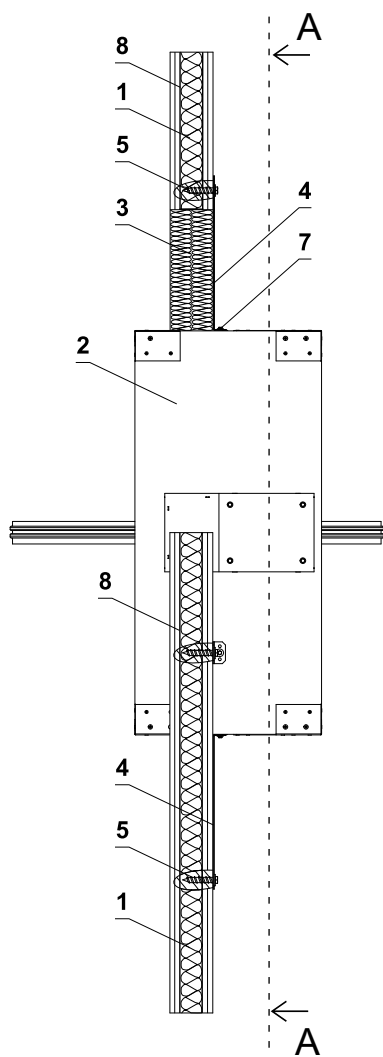

View A - grid from "C" profile

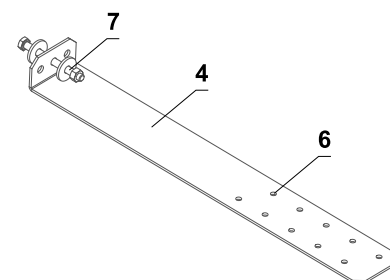

\* **ATTENTION TO THE LOCATION OF THE JOINT !**  
Screws and nuts must not impede the free rotation of Blades.

- 1 Gypsum wall construction
- 2 SEDM
- 3 Ablative Coated Batt
- 4 Fixing element/steel holder for connecting damper to the wall (optional accessories MANDIK, a.s. or sheet metal min. thickness 2 mm and min. width 60 mm)
- 5 Screw UNI 6x60 mm
- 6 Installation holes
- 7 M8 bolt assembly (bolt M8x55 mm, 2 pcs large washer M8, nut M8) \*
- 8 Gypsum grid from "C" profile

■ The method of mounting must meet the minimum requirements for attachment in accordance with national regulations.

## Example of duct connection

### Flange connection

Connection to smoke extract duct acc. to BS EN 1366-8 (MULTI) / to BS EN 1366-9 (SINGLE)

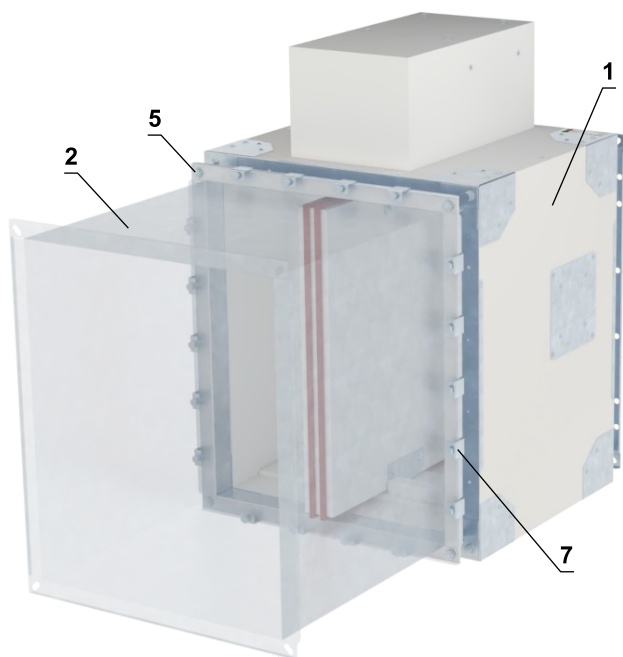
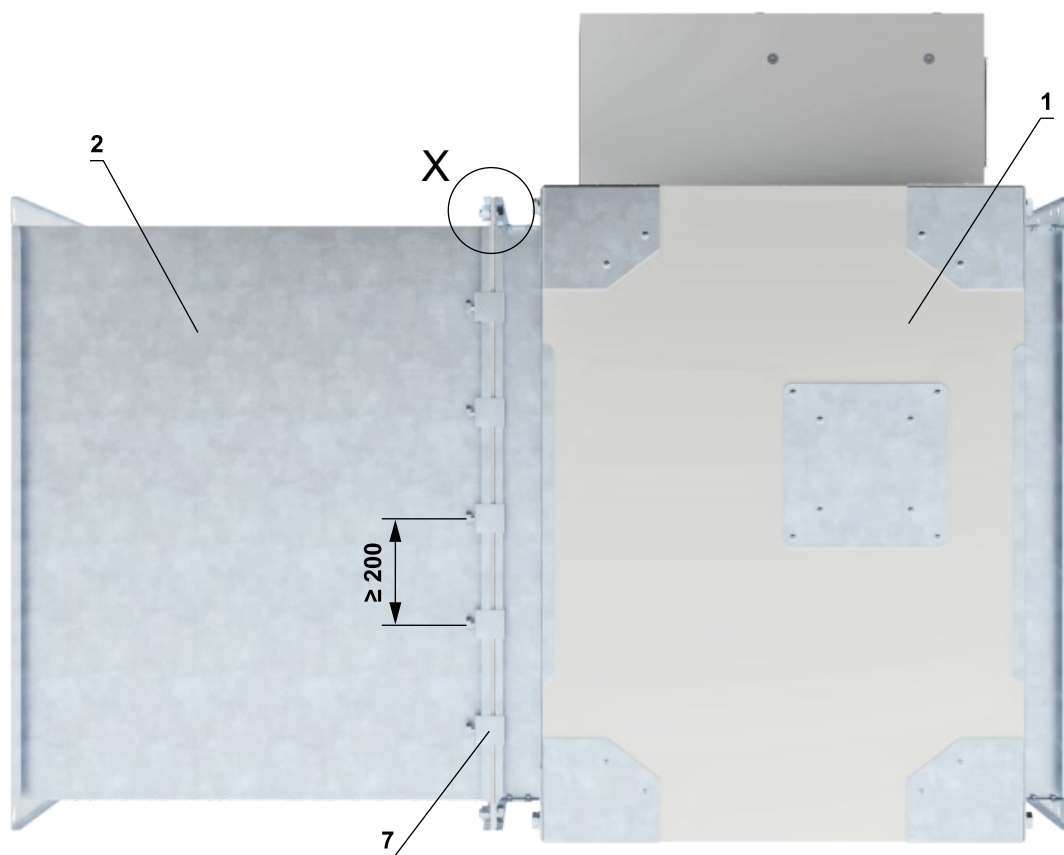

### Electrically conductive connection

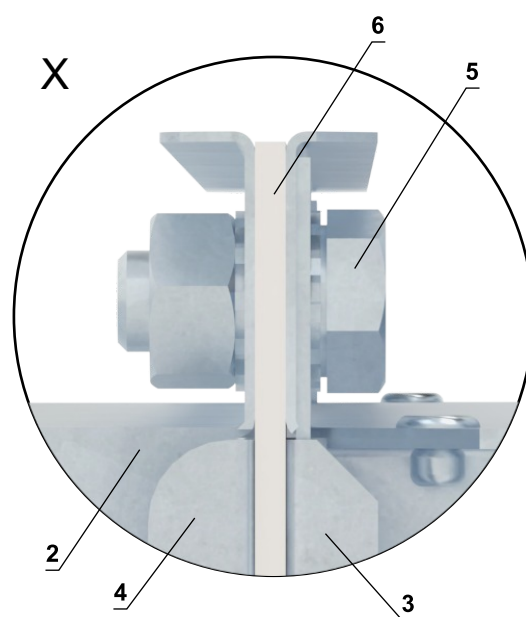

- 1 SEDM
- 2 Connecting air duct MULTI
- 3 Flange of SEDM
- 4 Flange of duct
- 5 M8 bolt assembly (bolt M8x20 mm, 2 pcs lock washer M8, nut M8) \*
- 6 Ceramic selfadhesive sealing tape - around the duct circumference (type according to duct manufacturer instructions instructions)
- 7 M8 C-clamps - maximum spacing of C-clamps 200 mm (type according to duct manufacturer instructions instructions)

\* min. one connection must be electrically conductive

**Example of connection SEDM damper in steel duct MULTI with insulation ROCKWOOL FIREPRO DuctRock Slab**

Connect the joints of stone wool plates with ROCKWOOL FIREPRO Glue, secure with screws and welding pins at max. spacings of 250 mm. Board joints must be covered using ROCKWOOL black aluminium foil tape. Follow duct supplier's instructions and insulation.

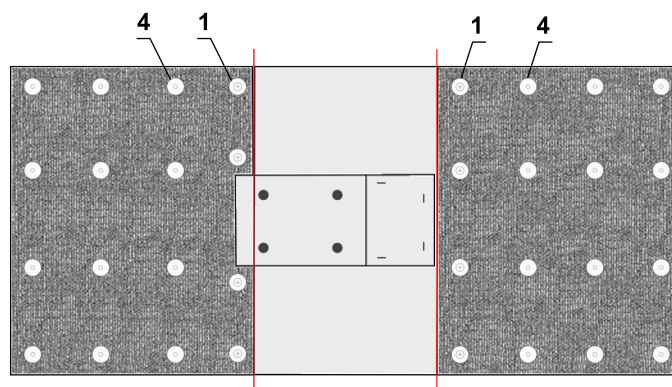
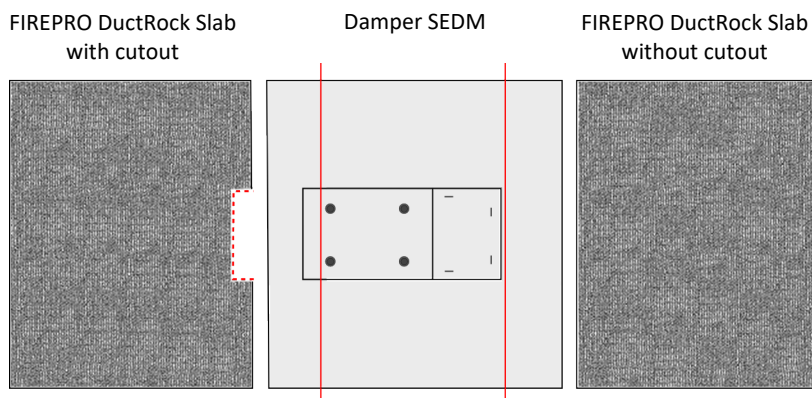
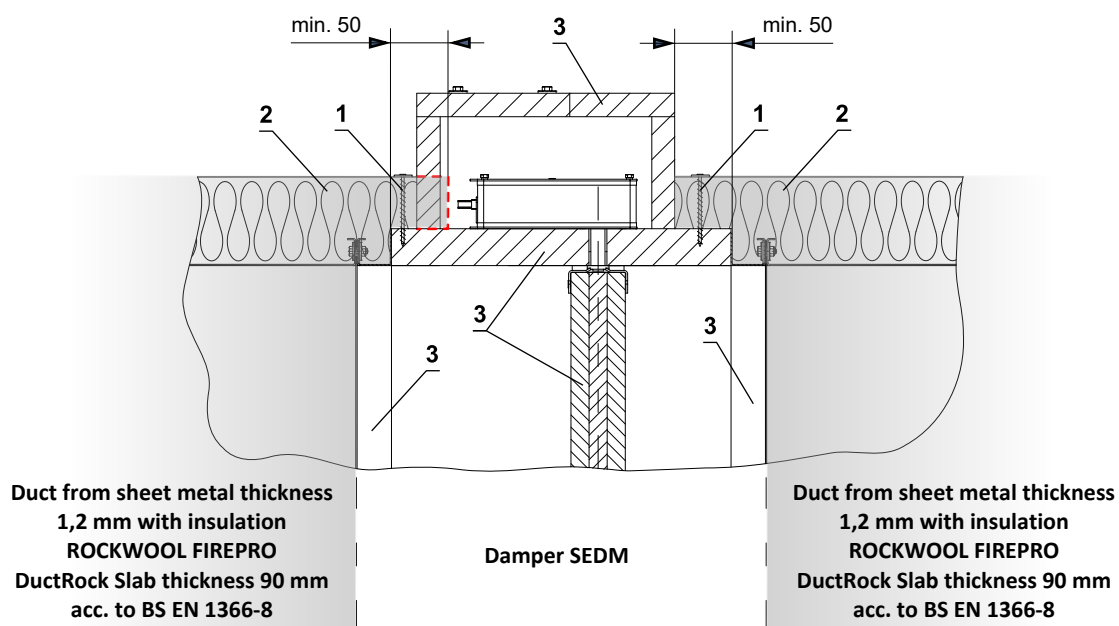

- 1 Universal screw min.  $\varnothing$ 5 mm, length 70 mm, max. spacing 250 mm
- 2 ROCKWOOL FIREPRO DuctRock Slab th. 90 mm acc. to BS EN 1366-8
- 3 Part of SEDM
- 4 Welding pins at max. spacings of 250 mm

Insulation cut-out area around the actuator cover

**Example installed SEDM damper in fire separating construction and connection to steel duct MULTI**

Connect the joints of stone wool plates with ROCKWOOL FIREPRO Glue, secure with screws and welding pins at max. spacings of 250 mm. Board joints must be covered using ROCKWOOL black aluminium foil tape. Follow duct supplier's instructions and insulation.

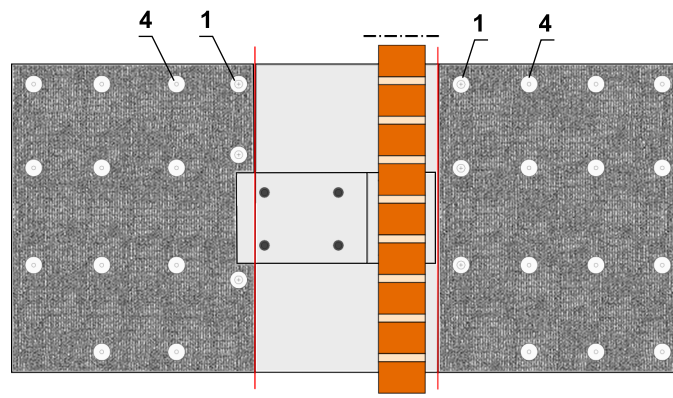
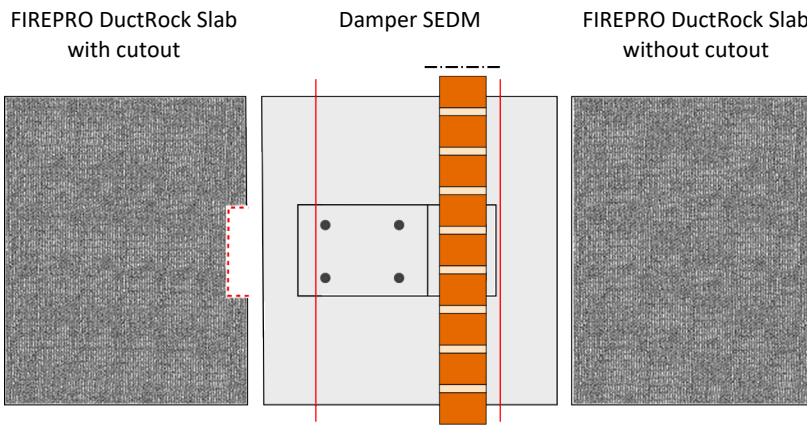
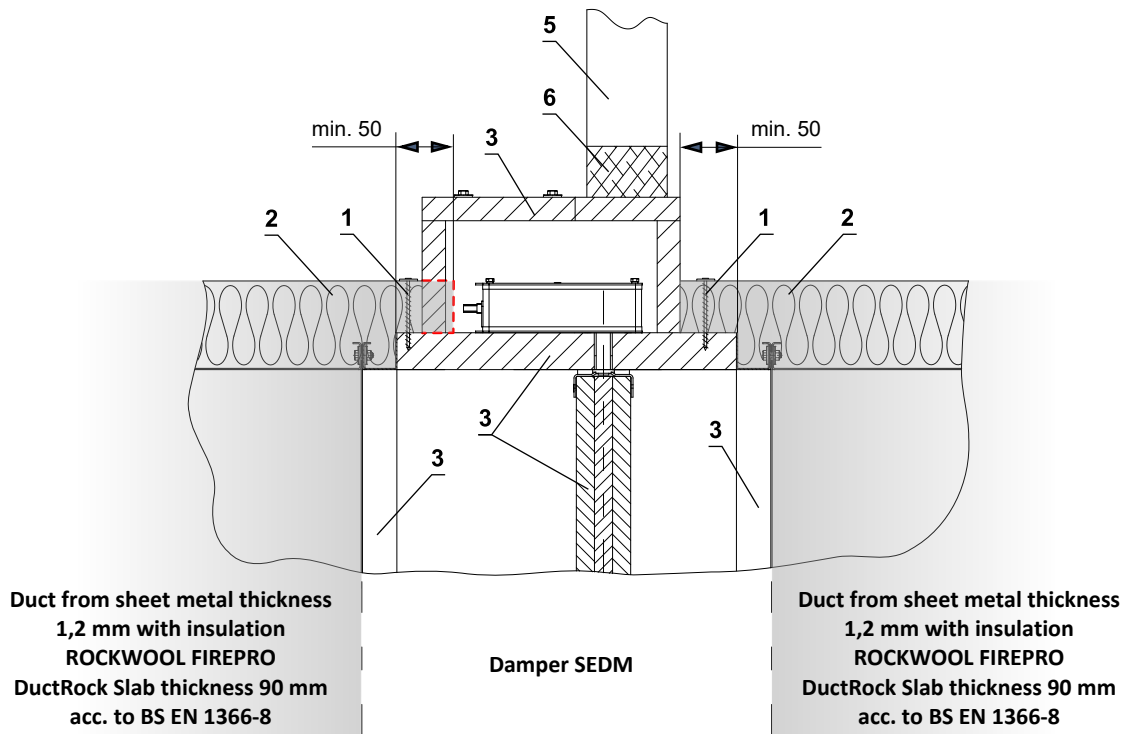

- 1 Universal screw min.  $\varnothing$ 5 mm, length 70 mm, max. spacing 250 mm
- 2 ROCKWOOL FIREPRO DuctRock Slab th. 90 mm acc. to BS EN 1366-8
- 3 Part of SEDM
- 4 Welding pins at max. spacings of 250 mm
- 5 Wall\*
- 6 Penetration

\* Same rules apply to mounting and connection in the ceiling construction

Insulation cut-out area around the actuator cover

## VI. ACCESSORIES

### Cover grille KMM

- The grilles type KMM (TPM 002/96) can be used to close smoke control dampers.
- During grilles installation blade overlaps has to be respected → see page 11.
- These grilles are available in all sizes of the smoke control dampers.
- For KMM grille ensure blade overlaps do not strike KMM- spacer duct may be required - not included in delivery.
- Free area value for KMM is 78%.

### SEDM with cover grille without flange

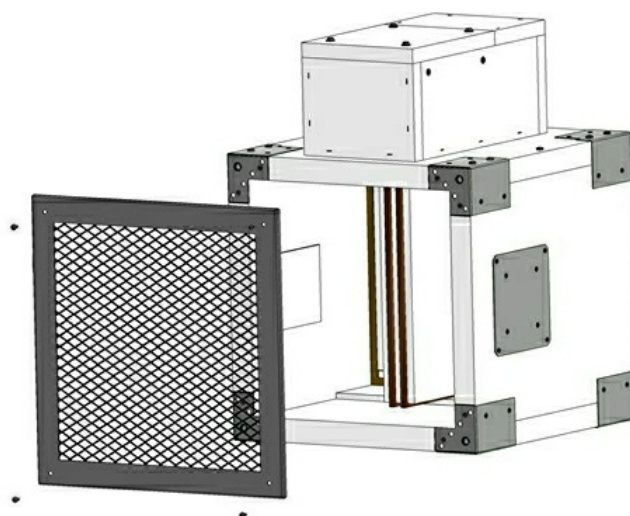
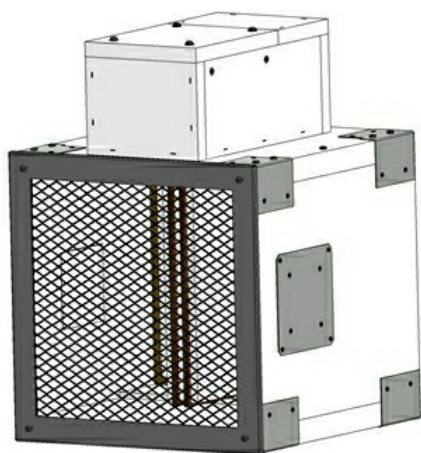

### SEDM with cover grille and with flange

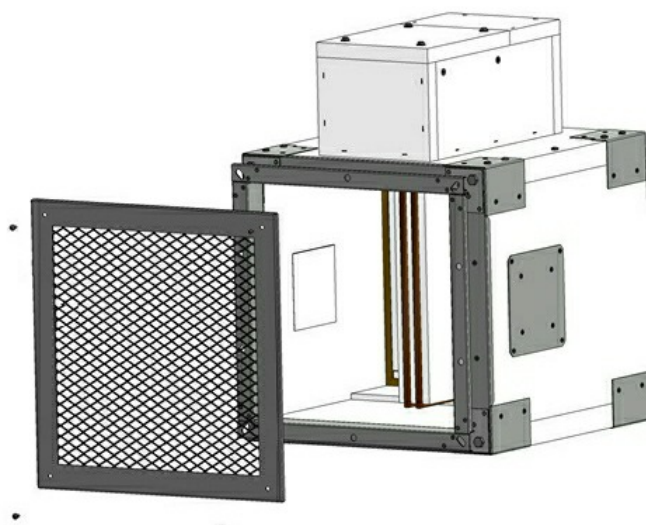
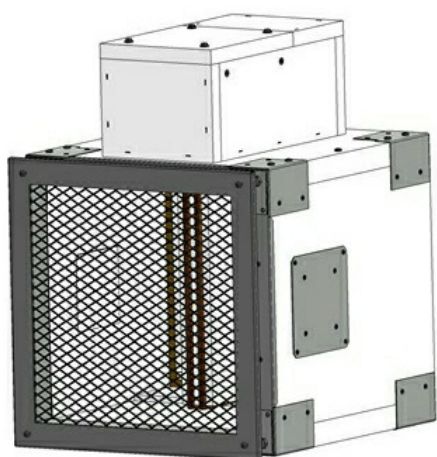

## VII. TECHNICAL DATA

### Pressure loss

#### Pressure loss calculation

$$\Delta p = \xi \cdot \rho \cdot \frac{w^2}{2}$$

$\Delta p$	[Pa]	pressure loss
$w$	[m/s]	air flow speed in nominal damper section
$\rho$	[kg/m <sup>3</sup> ]	air density
$\xi$	[-]	coefficient of local pressure loss for the nominal damper section → see page 47

#### Determination of pressure loss by using diagram $\rho = 1,2 \text{ kg/m}^3$

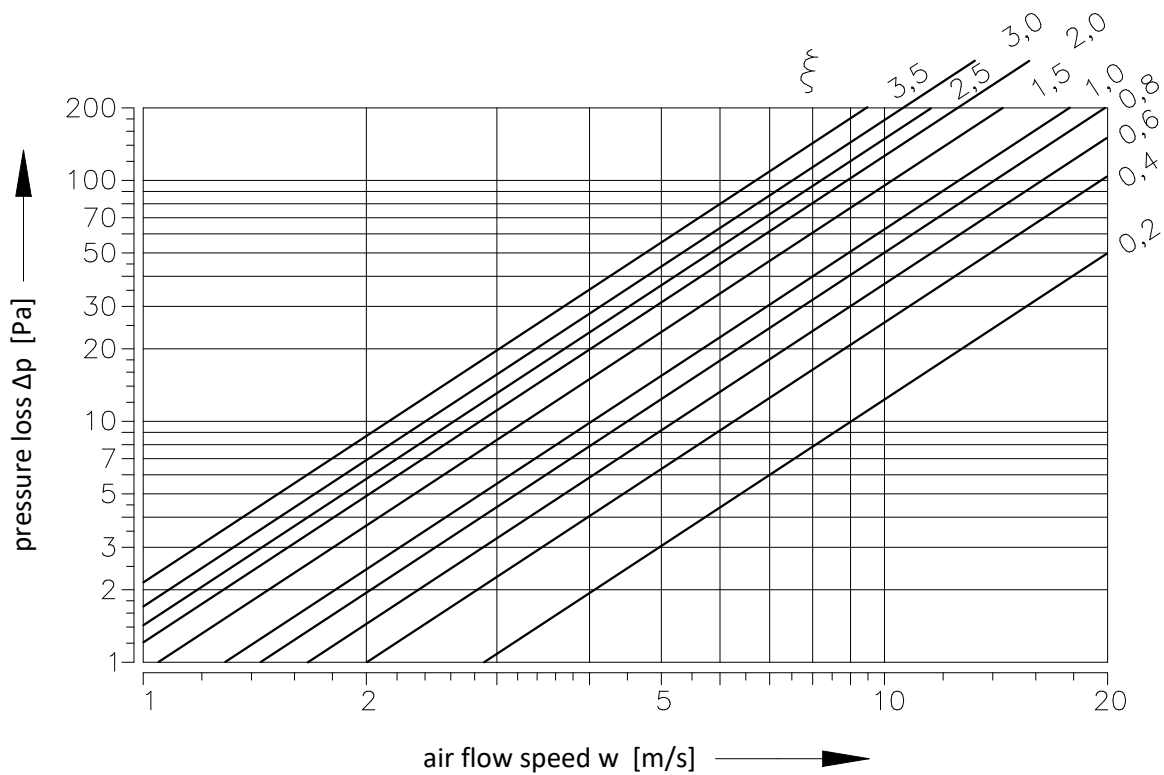

Coefficient of local pressure loss

B											
A	180	200	225	250	280	300	315	355	400	450	500
180	3,1433	2,5092	2,0162	1,6711	1,4773	1,3192	1,1951	1,0336	0,9095	0,8126	0,7429
200	2,9529	2,3545	1,9584	1,5657	1,3991	1,2512	1,1186	0,9673	0,8500	0,7582	0,6919
225	2,7795	2,2032	1,8326	1,4909	1,3226	1,1594	1,0438	0,9231	0,8143	0,7157	0,6562
250	2,6401	2,1012	1,7204	1,3923	1,2172	1,0795	0,9911	0,8568	0,7514	0,6698	0,6120
280	2,5721	2,0417	1,6677	1,3413	1,1577	1,0506	0,9333	0,8313	0,7242	0,6375	0,5984
300	2,5075	1,9822	1,5725	1,2784	1,1373	1,0081	0,9078	0,8075	0,7055	0,6239	0,5627
315	2,4055	1,9108	1,5283	1,2376	1,0897	0,9843	0,8806	0,7752	0,6800	0,6052	0,5525
355	2,3103	1,8343	1,4552	1,2121	1,0676	0,9265	0,8602	0,7412	0,6511	0,5797	0,5287
400	2,2304	1,7697	1,3787	1,1679	1,0217	0,9044	0,8279	0,7140	0,6256	0,5576	0,5083
450	2,1607	1,7153	1,3413	1,1305	1,0013	0,8823	0,8007	0,6902	0,6052	0,5389	0,4913
500	2,1080	1,6711	1,3362	1,1016	0,9452	0,8483	0,7633	0,6715	0,5882	0,5236	0,4777
550	2,0723	1,6507	1,2971	1,0829	0,9231	0,8194	0,7514	0,6613	0,5797	0,5185	0,4726
560	2,0587	1,6320	1,2886	1,0744	0,9061	0,8211	0,7429	0,6545	0,5729	0,5100	0,4658
600	2,0247	1,6116	1,2801	1,0659	0,8959	0,8041	0,7327	0,6443	0,5627	0,5066	0,4590
630	2,0128	1,5946	1,2733	1,0489	0,8857	0,7871	0,7259	0,6392	0,5593	0,4981	0,4539
650	2,0043	1,5742	1,2546	1,0421	0,8687	0,7786	0,7225	0,6324	0,5559	0,4947	0,4505
700	1,9873	1,5674	1,2512	1,0319	0,8517	0,7701	0,7157	0,6290	0,5508	0,4913	0,4471
710	1,9720	1,5623	1,2274	1,0268	0,8534	0,7548	0,7089	0,6256	0,5474	0,4879	0,4437
750	1,9567	1,5419	1,2172	1,0183	0,8483	0,7497	0,6987	0,6188	0,5406	0,4845	0,4386
800	1,9380	1,5351	1,2087	1,0081	0,8432	0,7446	0,6953	0,6137	0,5372	0,4777	0,4352
900	1,9074	1,5096	1,2053	0,9911	0,8228	0,7259	0,6834	0,6035	0,5270	0,4692	0,4284
1000	1,8836	1,4909	1,2002	0,9792	0,7939	0,7106	0,6749	0,5950	0,5202	0,4641	0,4216
1100	1,8615	1,4739	1,1917	0,9673	0,7752	0,7004	0,6664	0,5865	0,5134	0,4573	0,4165
1250	1,8428	1,4569	1,1781	0,9554	0,7735	0,6987	0,6579	0,5814	0,5083	0,4522	0,4114
1400	1,8241	1,4433	1,1696	0,9469	0,7718	0,6970	0,6511	0,5746	0,5032	0,4471	0,4080
1500	1,8139	1,4348	1,1611	0,9418	0,7684	0,6936	0,6477	0,5712	0,4998	0,4454	0,4046
1600	1,8054	1,4280	1,1169	0,9367	0,7667	0,6902	0,6443	0,5678	0,4981	0,4420	0,4029

B											
A	550	560	600	630	650	700	710	750	800	900	1000
180	0,6987	0,6800	0,6477	0,6273	0,5984	0,5933	0,5831	0,5627	0,5474	0,5168	0,4947
200	0,6545	0,6341	0,6052	0,5848	0,5627	0,5525	0,5440	0,5304	0,5100	0,4828	0,4607
225	0,6188	0,5916	0,5712	0,5559	0,5355	0,5287	0,5134	0,5032	0,4777	0,4556	0,4318
250	0,5882	0,5610	0,5372	0,5168	0,4998	0,4913	0,4862	0,4726	0,4488	0,4335	0,4063
280	0,5559	0,5304	0,5151	0,4947	0,4828	0,4794	0,4726	0,4471	0,4301	0,4216	0,3927
300	0,5321	0,5202	0,4947	0,4743	0,4675	0,4624	0,4573	0,4267	0,4182	0,4029	0,3808
315	0,5134	0,5049	0,4692	0,4658	0,4471	0,4386	0,4318	0,4097	0,4046	0,3825	0,3655
355	0,4896	0,4828	0,4556	0,4454	0,4318	0,4216	0,4131	0,3961	0,3876	0,3655	0,3485
400	0,4743	0,4641	0,4471	0,4284	0,4182	0,4097	0,3978	0,3842	0,3723	0,3519	0,3349
450	0,4556	0,4488	0,4352	0,4131	0,4046	0,3927	0,3842	0,3757	0,3587	0,3383	0,3230
500	0,4505	0,4369	0,4182	0,4012	0,3876	0,3791	0,3723	0,3587	0,3485	0,3298	0,3145
550	0,4437	0,4267	0,4148	0,3978	0,3808	0,3757	0,3655	0,3519	0,3451	0,3247	0,3111
560	0,4386	0,4250	0,4097	0,3910	0,3757	0,3723	0,3638	0,3451	0,3400	0,3213	0,3060
600	0,4369	0,4199	0,3978	0,3876	0,3672	0,3638	0,3587	0,3434	0,3366	0,3162	0,3026
630	0,4301	0,4148	0,3927	0,3825	0,3621	0,3570	0,3536	0,3417	0,3315	0,3128	0,2992
650	0,4267	0,4097	0,3927	0,3808	0,3604	0,3553	0,3502	0,3400	0,3298	0,3111	0,2975
700	0,4250	0,4080	0,3859	0,3791	0,3587	0,3536	0,3485	0,3383	0,3281	0,3077	0,2941
710	0,4216	0,4063	0,3808	0,3740	0,3570	0,3502	0,3468	0,3349	0,3247	0,3060	0,2924
750	0,4199	0,4029	0,3757	0,3706	0,3553	0,3468	0,3434	0,3315	0,3213	0,3026	0,2873
800	0,4182	0,3978	0,3757	0,3655	0,3536	0,3451	0,3400	0,3281	0,3179	0,2992	0,2856
900	0,4148	0,3910	0,3757	0,3604	0,3519	0,3417	0,3332	0,3179	0,3128	0,2941	0,2805
1000	0,4012	0,3859	0,3706	0,3553	0,3502	0,3349	0,3281	0,3145	0,3077	0,2907	0,2771
1100	0,3927	0,3808	0,3587	0,3502	0,3417	0,3298	0,3247	0,3094	0,3043	0,2856	0,2737
1250	0,3876	0,3757	0,3536	0,3451	0,3383	0,3281	0,3213	0,3077	0,2992	0,2822	0,2703
1400	0,3825	0,3723	0,3502	0,3417	0,3332	0,3264	0,3179	0,3043	0,2975	0,2805	0,2669
1500	0,3791	0,3706	0,3485	0,3400	0,3298	0,3247	0,3162	0,3026	0,2958	0,2788	0,2652
1600	0,3774	0,3672	0,3451	0,3383	0,3264	0,3230	0,3145	0,2992	0,2941	0,2771	0,2635

Noise data - level of acoustic output corrected with filter A

Air velocity 4 m/s Level of acoustic output [dB]																						
B																						
A	180	200	225	250	280	300	315	355	400	450	500	550	560	600	630	650	700	710	750	800	900	1000
180	56	49	48	46	44	42	41	41	40	40	40	40	40	40	40	40	40	38	38	37	38	38
200	52	48	45	44	41	41	41	41	40	40	39	39	39	38	38	38	37	37	37	36	37	37
225	50	47	45	40	40	40	41	40	39	39	39	38	38	36	36	37	37	36	36	36	36	36
250	49	45	44	42	40	40	40	39	38	38	37	37	37	37	37	37	37	37	37	36	36	36
280	47	45	40	40	40	39	38	37	37	37	37	37	37	36	36	36	36	36	36	36	35	35
300	47	44	40	40	39	39	39	37	36	37	37	37	37	35	35	35	35	35	35	36	36	36
315	47	44	40	40	39	39	37	37	37	36	36	36	36	36	36	36	36	35	35	35	34	34
355	46	43	40	39	39	37	37	36	36	36	36	35	35	35	35	35	35	35	35	33	34	35
400	47	42	40	39	37	37	36	36	36	35	35	35	35	35	35	35	34	34	34	34	33	33
450	45	42	40	39	37	37	37	36	35	35	35	35	35	35	35	35	35	35	35	34	34	34
500	45	40	39	38	37	36	36	36	35	35	35	34	34	33	33	34	34	34	33	33	33	33
550	44	40	40	38	37	37	36	36	35	35	34	34	34	34	34	33	33	33	33	33	33	33
560	44	40	40	38	37	37	36	35	35	35	34	34	34	34	34	34	33	33	33	33	33	33
600	44	40	38	36	36	36	36	36	35	35	35	35	35	33	33	33	33	32	32	32	32	32
630	44	40	38	37	36	36	36	35	35	35	34	34	34	34	34	34	33	33	33	33	32	32
650	44	40	38	37	36	36	36	35	35	35	34	34	34	34	34	34	33	33	33	33	33	33
700	43	39	38	38	36	36	36	37	35	36	34	34	34	34	34	33	33	33	33	33	33	33
710	43	39	38	38	36	36	36	37	35	36	34	34	34	34	34	33	33	33	33	33	33	33
750	43	40	38	37	36	35	35	34	34	34	34	34	33	33	33	33	33	33	33	33	33	33
800	43	40	37	37	36	36	35	34	34	34	34	33	33	33	33	33	33	33	33	33	33	33
900	43	40	37	36	36	36	35	34	34	34	34	33	33	33	33	33	33	33	33	33	33	33
1000	43	39	37	37	37	36	35	35	34	34	34	33	33	33	33	33	33	33	33	33	33	33
1100	42	39	37	37	37	35	35	34	34	34	33	33	33	33	33	33	33	33	32	32	32	32
1250	42	39	37	37	37	35	35	34	34	34	34	33	33	33	33	33	33	33	32	32	32	32
1400	42	39	37	37	37	35	35	34	34	34	33	33	33	33	33	33	33	33	32	32	32	31
1500	42	39	37	37	37	35	35	34	34	34	33	33	33	33	33	33	33	33	32	32	32	31
1600	42	39	37	37	37	35	35	34	34	34	33	33	33	33	33	33	33	33	32	32	32	31

Air velocity 5 m/s  
Level of acoustic output [dB]

B																						
A	180	200	225	250	280	300	315	355	400	450	500	550	560	600	630	650	700	710	750	800	900	1000
180	>55	55	53	52	49	47	48	47	47	47	46	46	46	46	46	45	45	45	45	45	45	45
200	>55	55	52	49	48	48	47	47	47	45	45	45	44	44	44	44	45	45	45	45	45	45
225	>55	54	50	48	47	47	47	45	44	44	44	44	44	44	44	44	44	44	44	44	44	43
250	>55	52	49	48	47	46	46	44	44	44	44	44	44	44	43	43	43	43	43	43	43	43
280	54	50	49	47	46	45	45	44	44	44	43	43	43	43	42	42	42	42	42	42	42	42
300	54	49	47	46	45	45	44	44	43	43	43	43	43	42	42	42	42	41	42	42	42	41
315	54	51	48	47	45	45	44	44	44	43	43	42	42	41	41	41	41	41	41	41	41	41
355	54	50	48	45	44	43	43	43	42	42	42	41	41	41	41	41	41	41	41	41	40	40
400	54	49	46	45	43	43	43	43	42	42	41	40	40	40	40	40	40	40	40	40	40	40
450	52	47	46	43	42	42	42	41	41	40	40	40	40	40	40	40	40	40	40	39	39	39
500	51	48	46	44	43	43	43	41	41	40	40	40	40	40	40	40	40	40	39	39	39	39
550	49	47	46	44	43	43	42	41	40	40	40	40	40	40	40	39	39	39	39	39	39	38
560	49	47	46	44	43	43	42	41	40	40	40	40	40	40	40	39	39	39	39	39	39	38
600	50	47	45	43	43	42	42	41	40	40	40	40	40	40	39	39	39	39	39	38	38	38
630	50	48	45	43	43	42	42	41	40	40	40	40	40	40	40	40	40	40	38	38	38	38
650	50	48	45	43	42	42	42	41	40	40	40	40	39	39	39	39	39	38	38	38	38	38
700	50	48	45	42	42	42	42	41	40	40	40	40	39	39	39	39	39	38	38	38	38	38
710	50	48	45	42	42	42	42	41	40	40	40	40	39	39	39	39	39	38	38	38	38	38
750	50	47	45	42	42	42	42	41	40	40	40	40	39	39	39	39	39	38	38	38	38	38
800	50	47	45	42	42	42	42	41	40	40	40	40	39	39	39	39	39	38	38	38	38	38
900	49	47	44	42	42	42	41	40	40	40	40	39	39	39	39	39	38	38	38	38	38	38
1000	49	47	43	42	42	42	40	40	40	40	40	39	39	39	39	38	38	38	38	38	38	38
1100	49	47	43	42	42	42	40	40	40	40	40	39	39	39	39	38	38	38	38	38	38	38
1250	49	47	43	42	42	42	40	40	40	40	39	39	39	39	38	38	38	38	38	38	38	38
1400	48	46	43	42	42	41	40	40	40	39	38	38	38	38	38	38	38	38	38	38	38	37
1500	48	46	43	42	41	41	40	40	40	39	38	38	38	38	38	38	38	38	38	38	38	37
1600	48	46	43	42	41	41	40	40	40	39	38	38	38	38	38	38	38	38	38	38	38	37

Air velocity 6 m/s  
Level of acoustic output [dB]

B																						
A	180	200	225	250	280	300	315	355	400	450	500	550	560	600	630	650	700	710	750	800	900	1000
180	>55	>55	>55	>55	55	54	54	54	54	52	52	52	52	52	52	52	52	52	51	51	51	51
200	>55	>55	>55	55	54	54	53	53	52	51	50	50	50	50	50	50	50	50	50	50	50	48
225	>55	>55	>55	54	52	52	52	51	50	50	49	48	48	48	48	48	48	48	48	48	47	47
250	>55	>55	55	53	52	52	51	50	50	49	48	48	48	47	47	47	47	47	47	47	47	47
280	>55	>55	54	52	51	50	50	49	48	48	48	47	46	46	46	46	46	46	46	46	46	46
300	>55	>55	54	52	50	50	50	48	47	47	46	46	46	46	46	46	46	46	46	46	47	45
315	>55	55	53	52	50	49	50	48	47	46	46	46	46	46	46	46	46	46	47	47	46	46
355	>55	55	53	51	50	49	48	47	47	46	46	46	46	46	46	46	46	46	46	46	46	46
400	>55	54	52	50	49	48	48	47	45	45	45	45	45	45	45	45	45	45	45	45	45	45
450	>55	54	51	50	48	48	47	46	45	45	45	45	45	45	45	45	45	45	45	45	45	45
500	55	54	51	49	48	48	47	45	45	45	45	45	45	45	45	45	45	45	45	45	43	43
550	55	53	50	50	48	47	45	45	45	45	45	45	45	45	45	45	45	45	45	44	44	44
560	55	53	50	50	48	47	45	45	45	45	45	45	45	45	45	45	45	45	45	44	44	44
600	55	53	50	50	48	47	45	45	45	45	45	45	45	44	44	44	44	44	44	44	44	44
630	55	53	50	49	48	47	45	45	45	45	45	45	44	44	44	44	44	44	44	44	44	44
650	55	52	50	49	48	47	45	45	45	45	45	45	44	44	44	44	44	44	43	43	43	43
700	55	52	50	48	48	46	46	45	45	45	45	45	44	44	44	44	44	44	43	43	43	43
710	55	52	50	48	48	46	46	45	45	45	45	45	44	44	44	44	44	44	43	43	43	43
750	55	52	50	48	48	46	45	45	45	45	45	45	44	44	44	44	44	44	43	43	43	43
800	55	52	50	48	48	46	45	45	45	45	45	45	44	44	44	44	43	43	43	43	43	43
900	55	52	49	48	47	45	45	45	45	45	45	44	43	43	43	43	43	43	43	43	43	43
1000	55	52	49	48	47	45	45	45	45	45	44	44	44	43	43	43	43	43	43	43	43	43
1100	54	52	49	48	46	45	45	45	45	44	44	44	44	43	43	43	43	43	43	43	43	43
1250	54	52	49	47	45	45	45	45	45	44	44	44	44	43	43	43	43	43	43	43	43	43
1400	54	52	48	48	46	44	44	44	45	44	43	43	43	43	43	43	43	43	43	43	43	42
1500	54	52	48	48	45	44	44	44	45	44	43	43	43	43	43	43	43	43	43	43	42	42
1600	54	52	48	48	45	44	44	45	45	45	43	43	43	43	43	43	43	43	43	42	42	42

Air velocity 7 m/s  
Level of acoustic output [dB]

B																						
A	180	200	225	250	280	300	315	355	400	450	500	550	560	600	630	650	700	710	750	800	900	1000
180	>61	>61	>61	>61	61	60	60	58	58	57	56	56	56	55	55	55	55	55	55	56	55	55
200	>61	>61	>61	>61	59	58	58	57	56	55	55	55	55	55	55	55	55	54	54	54	54	54
225	>61	>61	>61	60	57	56	56	55	55	55	54	54	53	53	53	53	53	53	53	53	53	53
250	>61	>61	>61	58	56	56	56	55	54	53	53	53	53	53	52	52	52	52	52	53	52	52
280	>61	>61	60	57	56	55	55	54	53	52	52	52	51	51	51	51	51	51	51	51	50	50
300	>61	61	58	57	55	54	54	53	53	52	52	52	52	52	52	50	50	50	50	50	50	50
315	>61	61	57	56	55	55	54	53	52	52	51	51	51	51	50	50	50	50	50	49	49	49
355	>61	61	57	55	54	53	53	52	52	52	51	50	50	50	50	50	49	49	49	48	48	48
400	>61	60	57	55	53	53	53	52	51	51	49	49	49	49	49	48	48	48	48	48	48	48
450	>61	59	56	54	52	52	52	51	50	50	50	48	48	48	48	48	48	48	48	48	48	48
500	60	58	55	54	53	52	52	50	50	50	48	48	48	48	48	48	48	48	48	48	48	48
550	60	58	55	54	53	52	52	50	50	48	48	48	48	48	48	48	48	48	48	48	48	48
560	60	58	55	54	53	52	52	50	50	48	48	48	48	48	48	48	48	48	48	48	48	48
600	60	58	55	54	52	52	51	50	49	48	48	48	48	48	48	48	48	48	48	48	48	48
630	60	58	55	53	51	51	51	50	49	48	48	48	48	48	48	48	48	48	48	48	48	48
650	60	58	55	53	52	51	51	50	49	48	48	48	48	48	48	48	48	48	48	48	48	48
700	59	58	55	53	52	51	51	50	49	48	48	48	48	48	48	48	48	48	48	48	48	48
710	59	58	55	53	52	51	51	50	49	48	48	48	48	48	48	48	48	48	48	48	48	48
750	59	58	55	53	52	51	51	50	49	48	48	48	48	48	48	48	48	48	48	48	48	48
800	59	58	55	53	52	51	51	50	49	48	48	48	48	48	48	48	48	48	48	48	48	48
900	58	56	53	53	52	50	50	48	48	47	48	48	48	48	48	48	48	48	48	48	47	47
1000	58	56	53	53	51	50	50	48	48	48	48	48	48	48	48	48	48	48	48	48	47	47
1100	58	56	53	53	51	50	50	48	48	48	48	48	48	48	48	48	48	48	48	47	47	47
1250	58	56	53	53	51	50	50	48	48	48	48	48	48	48	48	48	48	48	48	47	47	47
1400	58	56	53	52	51	50	48	48	47	47	47	47	47	47	47	47	47	47	47	47	47	46
1500	58	56	53	52	51	50	50	48	47	47	47	47	47	47	47	47	47	47	47	47	47	46
1600	58	56	53	52	51	50	50	48	47	47	47	47	47	47	47	47	47	47	47	47	47	46

Air velocity 8 m/s  
Level of acoustic output [dB]

B																						
A	180	200	225	250	280	300	315	355	400	450	500	550	560	600	630	650	700	710	750	800	900	1000
180	>63	>63	>63	>63	>63	>63	>63	63	62	61	61	60	60	60	60	60	60	60	60	60	60	59
200	>63	>63	>63	>63	>63	62	62	61	60	60	60	60	60	60	60	60	60	60	59	59	59	58
225	>63	>63	>63	>63	>63	61	61	60	60	58	58	58	58	58	58	58	58	58	58	57	57	57
250	>63	>63	>63	>63	61	60	60	59	58	58	57	57	57	57	57	57	57	57	56	56	56	56
280	>63	>63	>63	>63	59	59	59	58	58	57	57	56	56	56	56	56	56	56	56	55	55	54
300	>63	>63	62	61	59	59	59	58	57	56	56	55	55	55	55	55	55	55	55	54	54	54
315	>63	>63	62	61	59	59	58	57	57	56	55	55	55	55	55	55	55	55	55	55	54	54
355	>63	>63	63	59	58	58	57	56	55	55	54	54	54	54	54	54	53	53	53	53	53	53
400	>63	63	62	60	58	57	56	56	55	54	54	54	54	54	54	54	53	53	53	53	52	52
450	>63	63	60	58	57	56	56	55	55	55	54	53	53	53	53	53	53	53	53	53	52	52
500	>63	62	60	58	56	55	55	54	54	54	53	53	53	53	53	53	53	53	53	52	51	51
550	>63	62	59	58	56	56	55	55	54	53	53	53	53	53	53	53	53	53	52	52	51	51
560	>63	62	59	58	56	56	55	55	54	53	53	53	53	53	53	53	53	53	52	52	51	51
600	>63	62	59	58	56	55	55	54	54	53	53	53	53	53	52	52	52	51	51	51	50	50
630	>63	62	59	58	56	55	55	54	54	53	53	53	53	53	52	52	52	51	50	50	50	50
650	>63	61	59	58	56	55	55	54	54	53	53	53	52	51	51	51	51	51	50	50	50	50
700	63	62	59	57	56	55	55	54	54	53	53	53	52	51	51	50	50	50	50	50	49	49
710	63	62	59	57	56	55	55	54	54	53	53	53	52	51	51	50	50	50	50	50	49	49
750	63	62	59	57	56	55	55	54	54	53	52	52	52	51	50	50	50	50	50	50	50	49
800	62	60	57	57	56	55	54	54	54	52	52	52	52	51	51	50	50	50	50	50	50	49
900	62	60	57	56	55	55	54	53	53	52	52	51	51	51	50	50	50	50	50	50	50	50
1000	62	60	57	56	56	55	54	53	53	52	52	51	51	51	50	50	50	50	50	50	50	50
1100	62	60	57	56	56	55	54	53	53	52	51	51	51	50	50	50	50	50	50	50	50	50
1250	62	61	58	56	56	54	54	53	53	52	50	50	50	50	50	50	49	49	49	49	49	49
1400	62	61	57	56	56	53	54	53	53	50	50	50	50	50	50	50	49	49	49	49	49	49
1500	62	61	57	56	56	54	54	53	52	50	50	50	50	50	50	50	49	49	49	49	49	49
1600	62	61	57	56	56	54	54	53	52	50	50	50	50	50	50	50	49	49	49	49	49	49

Air velocity 9 m/s  
Level of acoustic output [dB]

B																						
A	180	200	225	250	280	300	315	355	400	450	500	550	560	600	630	650	700	710	750	800	900	1000
180	>65	>65	>65	>65	>65	>65	>65	>65	>65	65	64	64	64	64	64	64	64	64	64	63	63	63
200	>65	>65	>65	>65	>65	>65	>65	65	64	64	63	63	63	62	62	62	62	62	62	62	61	61
225	>65	>65	>65	>65	>65	>65	65	63	63	62	61	61	61	61	61	61	61	61	61	61	60	60
250	>65	>65	>65	>65	>65	65	65	63	62	61	60	60	60	60	60	60	60	60	60	60	60	60
280	>65	>65	>65	>65	64	63	62	61	61	60	60	60	60	59	59	59	59	59	59	59	58	58
300	>65	>65	>65	65	63	62	62	61	60	60	60	60	60	60	60	59	59	59	59	59	59	59
315	>65	>65	>65	64	63	62	61	61	60	60	60	60	60	59	59	59	59	59	59	59	59	58
355	>65	>65	>65	64	62	61	60	60	60	60	60	59	59	59	59	58	58	58	58	58	58	58
400	>65	>65	>65	63	61	60	60	59	58	58	58	58	58	58	58	58	58	58	58	57	57	57
450	>65	>65	65	63	60	60	60	59	58	58	58	57	57	57	57	57	57	57	57	56	56	56
500	>65	>65	64	61	60	60	60	59	58	57	57	57	57	57	56	56	56	56	56	56	55	55
550	>65	>65	62	62	60	60	58	57	58	58	57	57	57	56	56	56	56	56	56	56	55	55
560	>65	>65	62	62	60	60	58	57	58	58	57	57	57	56	56	56	56	56	56	56	55	55
600	>65	>65	62	62	60	59	58	58	58	57	56	56	56	56	56	56	55	55	55	55	55	55
630	>65	>65	62	62	60	59	58	58	58	57	56	56	56	56	56	56	55	55	55	55	55	55
650	>65	>65	62	62	59	59	58	58	58	57	56	56	56	56	56	56	55	55	55	55	55	55
700	>65	>65	62	61	59	59	58	58	57	56	55	55	55	55	55	55	55	55	55	55	55	54
710	>65	>65	62	61	59	59	58	58	57	56	55	55	55	55	55	55	55	55	55	55	55	54
750	>65	>65	62	61	59	59	58	57	57	56	55	55	55	55	55	55	55	55	55	55	55	55
800	>65	64	62	61	59	59	58	57	57	56	55	55	55	55	55	55	55	55	55	55	54	54
900	>65	64	62	60	60	59	58	57	57	55	55	55	55	55	55	55	54	55	55	55	54	54
1000	>65	64	60	60	58	58	58	57	57	55	55	55	55	55	55	55	55	55	55	55	54	54
1100	>65	64	60	59	58	58	57	57	57	55	55	55	55	55	55	55	55	55	55	55	54	54
1250	>65	64	60	59	58	58	57	57	56	55	55	55	55	55	54	54	54	54	54	54	54	53
1400	>65	64	61	60	58	58	57	57	56	56	55	55	55	55	55	54	54	54	54	54	53	53
1500	>65	64	60	60	58	58	56	56	56	56	55	55	55	55	55	54	54	54	53	53	53	53
1600	>65	64	60	60	58	58	56	56	56	56	55	55	55	55	55	54	54	54	53	53	53	53

## VIII. MATERIAL, FINISHING

- Damper casings and blades are made of fire resistant asbestos free boards made of mineral fibres.
- Fasteners are galvanized.
- Damper bodies and blades can be coated with Promat 2000 anti-moisture coating or Promat-SR anti-aggressive coating. Fasteners are galvanized.
- Any other requirements for the design shall be considered atypical and shall be addressed on an individual basis.

## IX. TRANSPORTATION AND STORAGE

### Logistic terms

- Dampers are delivered on a pallets. As standard, the dampers are wrapped in plastic foil for protection during transport and must not be used for long-term storage of the equipment. Changes in temperature during transport may cause condensation of water vapour inside the packaging and thereby conditions may arise inside the packaging that are suitable for corrosion of materials used in the equipment (e.g. white corrosion on zinc-coated items or mould on calcium silicate). Therefore, it is necessary to remove the transport packaging immediately after unloading to allow air to circulate around the product.
- The equipment must be stored in clean, dry, well ventilated and dust-free environment out of direct sunlight. ensuring protection against moisture and extremes of temperatures (minimum temperature +5°C) the equipment must be protected against mechanical and accidental damage prior to installation.
- Another required packaging system should be approved and agreed by manufacturer. Packaging material is not returnable in case that another packaging system (material) is required and used and it is not included into final price of damper.
- For unloading and further manipulation with the damper is necessary to use appropriate tooling (forklifts) due to damper weight. Dampers are fragile.
- Dampers are transported by box freight vehicles without direct weather impact, there must not occur any shocks and ambient temperature must not exceed +50°C. Dampers must be protected against impact when transported and manipulated. During transportation, the damper blade must be in the "CLOSED" position.
- Dampers are stored indoor in environment without any aggressive vapours, gases or dust. Indoor temperature must be in the range from -30°C to +50°C and maximum relative humidity 95% (avoid condensation on the damper body). Dampers must be protected against impact when transported and manipulated.

## X. ASSEMBLY, ATTENDANCE AND MAINTENANCE

- Assembly, maintenance and damper function check can be done only by qualified and trained person, i.e. "AUTHORIZED PERSON" according to the manufacturer documentation. All works done on the smoke control dampers must be done according international and local norms and laws.
- All effective safety standards and directives must be observed during damper assembly.
- To ensure reliable smoke control damper function it is necessary to avoid blocking the closing mechanism and contact surfaces with collected dust, fibre and sticky materials and solvents.
- Manual operation
  - Without power supply, the damper can be operated manually and fixed in any required position.

### **DANGER OF DAMAGE**

Always:

**REMOVE POWER BEFORE USING ALLEN KEY!  
NEVER USE A POWER TOOL!**

Both incorrect operations will damage the clutch Mechanism  
NO WARRANTY CLAIM!

### Electrical connection of the actuator in protection box

#### Protection box without slot or predrilled holes

- Drill two holes into the protection box (from outside to inside) and pull through field wiring cables (CAT 3 fire resistant cables as BS 8519) to connect to the actuator trailing lead inside the housing, using a standard screwed cable connector block, the protection box is made of calcium silicate plates.
- Procedure
  - Use drill (drill size acc. To suit connecting cable  $\varnothing + 2$  mm for seal up by mastic) and make two holes. It is possible to drill holes in any side of the housing.
  - Pull the heat resistant cable through the calcium silicate plate (wall) and connect with cables from actuator acc. to above mentioned electrical diagram.
  - Seal up the space around cable with fire resistant mastic (HILTI CFS-S ACR, PROMASTOP) or equivalent.
  - Let the mastic harden.

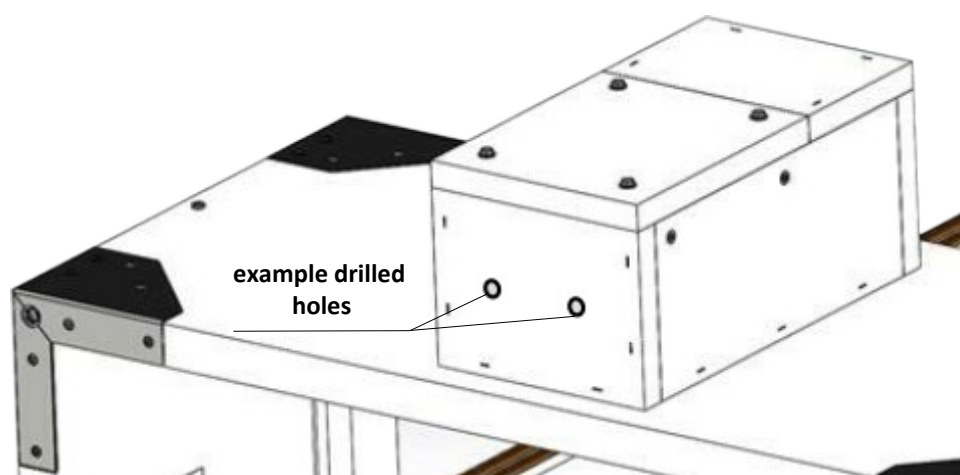

*Example of position of holes in the wall of the box, without pre-manufactured slot*

**Connection of the control module MDPM & MDCM interfaces inside protection box**

- Drill holes into the protection box (from outside to inside) and pull through field wiring cable (fire resistant cables) to connect control module. Protection box is made of calcium silicate insulating plates.
- Procedure:
  - Screw red box of MDPM/MDCM interface inside of the FIRE RATED housing to the back side, use pre drilled holes in red box and self-taping screws 4,8x25 mm. Minimum distance from walls 20 mm.
  - Use drill (drill size acc. to suit connecting cable  $\varnothing + 2$  mm for seal up by mastic) and make holes (min. pitch of the holes must be 30 mm), number of holes depends on the type of control module. **It is possible to drill holes in any side of the protection box.**
  - Pull the heat resistant cable through the calcium silicate insulating plate (wall) and connect with cables from control module.
  - Seal up the space around cable with fire resistant mastic (HILTI CFS-S ACR, PROMASTOP) or equivalent.
  - Let the mastic harden.
- Placement:
  - The FIRE RATED housing can be installed onto a wall.
  - For installation, drill 4 holes in the rear of the housing (from inside to outside) with a maximum hole diameter of 8,5mm, use fixing appropriate for the application. Seal all holes and gap between FIRE RATED housing and wall with firestop (HILTI CFS-S ACR, PROMASTOP).

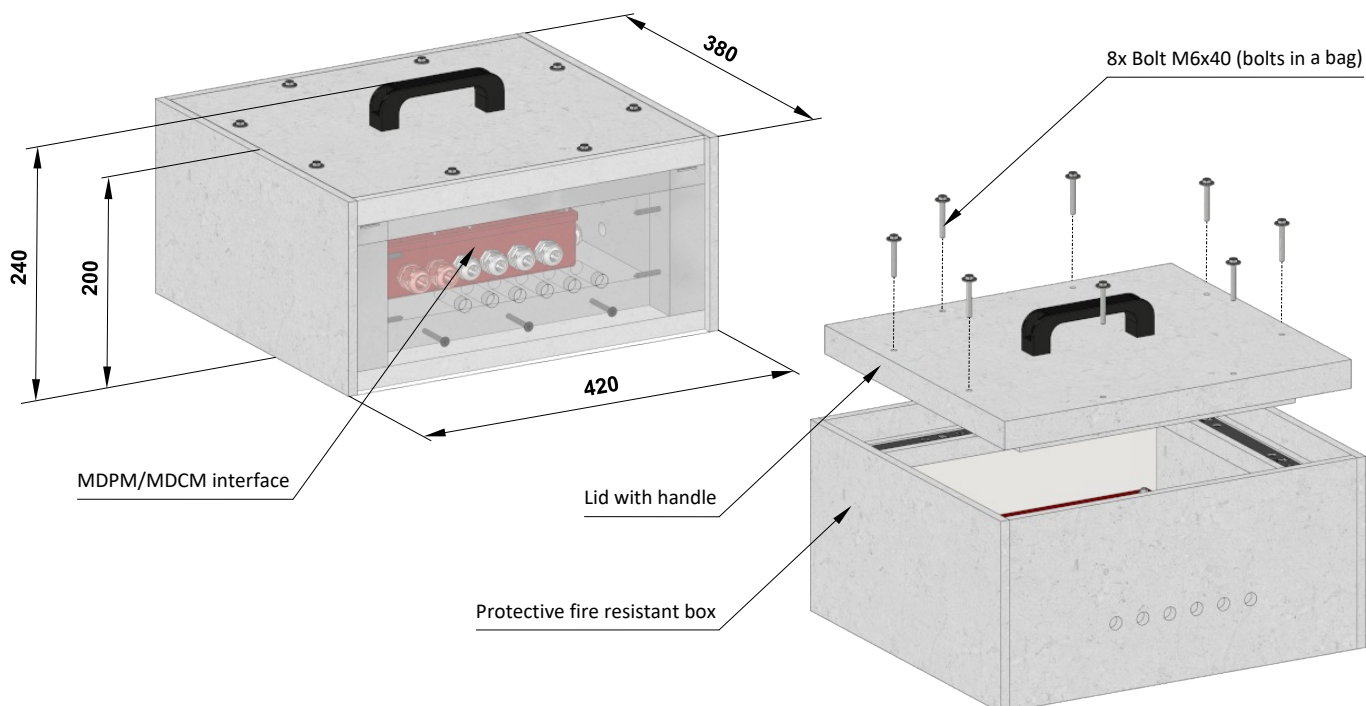
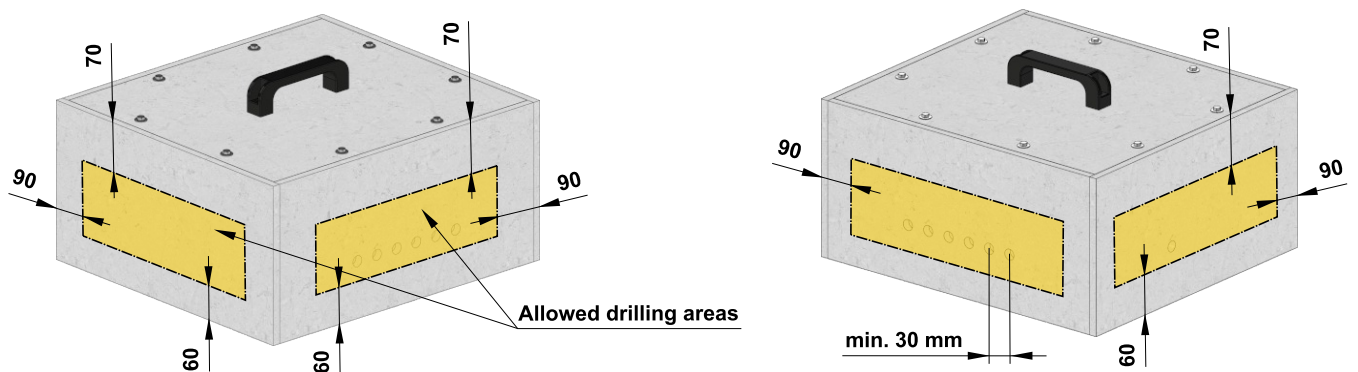

## Entry into service and revisions

- Before entering the dampers into operation after assembly and after sequential revisions, checks and functionality tests of all designs including operation of the electrical components must be successfully provided and finished. After entering into operation, these revisions must be done according to requirement set by national regulations.
- In case that dampers are found unable to serve for their function for any cause, it must be clearly marked. The operator is obliged to ensure that the damper is put into condition in which it is ready for function and meanwhile he is obliged to provide the fire protection by another appropriate way.
- Removing the inspection hole cover
  - Unscrew four of the edge screws to release the cover and then remove it from its original position.
- Results of regular checks, imperfections found and all-important facts connected with the damper function must be recorded in the "FIRE BOOK" and immediately reported to the operator.
- Before entering the dampers into operation after their assembly and by sequential checks, the following checks must be carried out for all designs.
- Visual inspection of proper damper integration, inside damper area, damper blade, contact surfaces and silicon sealing.

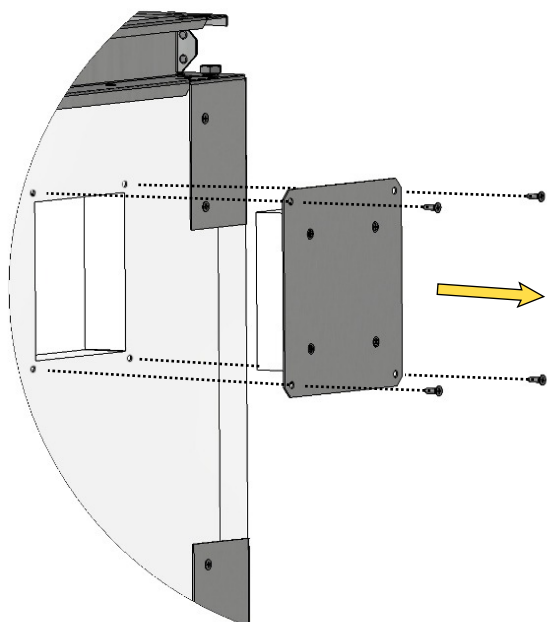

*Inspection hole detail*

- Ensure each damper is fully checked for operational capability, control should be initiated from the control system. Dampers blades should open and close correctly and operation should be visually inspected and documented prior to handover.

# XI. ORDERING INFORMATION

## Ordering key

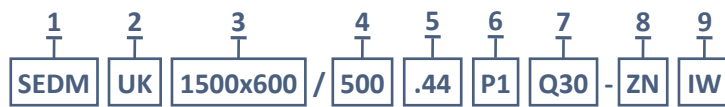

**EXAMPLE:**

**SEDM UK 1500x600/500 .44 P1 Q30-ZN IW**

Smoke control damper SEDM, dimension 1500x600 mm, built length 500 mm, control design with Drive open/Drive closed AC 230 V, flange on the blade side, flange dimension 30 mm, galvanized material variant, impregnation against humidity.

**1 | Type of smoke control damper - SEDM**

**2 | Country of destination**

**3 | Damper dimensions A x B → see pages 12 to 23**

**4 | Built length - 500 mm**

„A“ is the width of the damper  
„B“ is the height of the damper

**5 | Damper design**

.44	With actuating mechanism BEN, BEE, BE, InMax 50.75-S for 230V
.44M	With actuating mechanism BEN, BEE, BE, InMax 50.75-S + control module BRM-20-F for 230V
.44M2	With actuating mechanism BEN, BEE, BE, InMax 50.75-S + control module BRM2-20-F for 230V
.54	With actuating mechanism BEN, BEE, BE, InMax 50.75-S for 24V
.54M	With actuating mechanism BEN, BEE, BE, InMax 50.75-S + control module BRM-20-F for 24V
.54M2	With actuating mechanism BEN, BEE, BE, InMax 50.75-S + control module BRM2-20-F for 24V
.65 *	With actuating mechanism BEN (BEE)-SR for 24V
.67 **	With actuating mechanism BEN, BEE, BE-ST
.67M **	With actuating mechanism BEN, BEE, BE-ST + control module BRM-20-F-ST for 24V

\* Design is not available by using actuating mechanism BE, InMax 50.75-S

\*\* Design is not available by using actuating mechanism InMax 50.75-S

**6 | Accessories**

	Without flanges
P	With flanges on both sides
P1	Flange on the blade side
P2	Flange on the actuating mechanism side

**7 | Flange dimension**

Q30	Flange width 30 mm
-----	--------------------

**8 | Material**

ZN	Galvanized
----	------------

**9 | Surface treatment**

	Without surface treatment
IW	Damper blade impregnation, impregnating agent PROMAT 2000 - impregnation against humidity
IA	Damper blade impregnation, impregnating agent PROMAT SR - impregnation against chemical

Accessories

Flange



1| Accessory type - flange

3| Type of smoke control damper - SEDM

4| Damper dimensions A x B → see pages 12 to 23

2| Flange design

P	With flanges on both sides
P1	Flange on the blade side
P2	Flange on the actuating mechanism side

Installation holder



1| Accessory type - installation holder

2| Installation holder design

L = 500	Length 500 mm
L = 250	Length 250 mm

Data label

- Data label is placed on the damper casing (example)

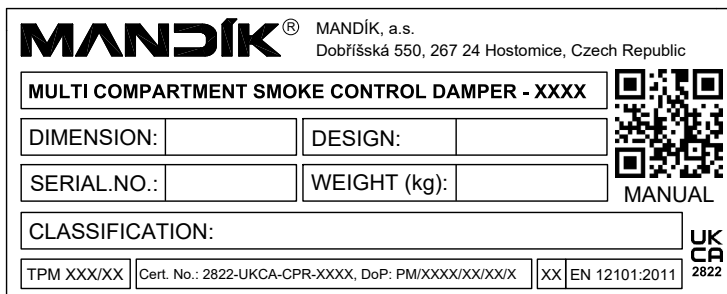

The producer reserves the right for innovations of the product.  
For actual product information see [www.mandik.co.uk](http://www.mandik.co.uk)

**MANDIK**<sup>®</sup>

[www.mandik.co.uk](http://www.mandik.co.uk)

*Manufacturer*

MANDIK, a. s. • Dobříšská 550 • 267 24 Hostomice • Czech Republic • Tel.: +420 311 706 742 • E-Mail: [mandik@mandik.cz](mailto:mandik@mandik.cz)

*Authorized representative*

MANDIK UK Ltd • 130 Aztec West • Bristol BS32 4UB • United Kingdom • Tel.: +44 117 4526376 • E-Mail: [help@mandik.co.uk](mailto:help@mandik.co.uk)